



Sacramento Regional Transit District Agenda

Revised 3/8/19
Addition of Item 4A

BOARD MEETING
5:30 P.M., MONDAY, MARCH 11, 2019
REGIONAL TRANSIT AUDITORIUM
1400 29TH STREET, SACRAMENTO, CALIFORNIA
Website Address: www.sacrt.com
(29th St. Light Rail Station/Bus 38, 67, 68)

ROLL CALL — Directors Budge, Hansen, Harris, Howell, Hume, Jennings, Miller, Nottoli, Schenirer, Serna and Chair Kennedy

Alternates: Directors Detrick, Kozlowski, Sander and Slowey

PLEDGE OF ALLEGIANCE

CONSENT CALENDAR

1. Motion: Approval of the Action Summary of February 25, 2019
2. Resolution: Delegating Authority to the General Manager/CEO to Award a Contract for the Purchase of Light Rail Vehicle Tire Kits (A. Carrasco)
3. Resolution: Approving a License Agreement with the City of Sacramento to Manage Sacramento Regional Transit District's Property Located at 510 12th Street and 1122 E Street, Sacramento, CA (B. Bernegger)
4. Resolution: Authorizing Travel Outside the United States for Patrick Kennedy, Chair, SacRT Board of Directors, to Represent Sacramento's Transportation Industry to Assist the Mayor of Sacramento to Lead a Regional Trade Mission to China Focused on Smart Cities (C. Brooks/L. Ham)
- 4A. Resolution: Approving the Second Amendment to the Contract with Urban Transportation Associates for the Purchase of Additional Automated Passenger Counters (R. Thorn/H. Li)

INTRODUCTION OF SPECIAL GUESTS

UNFINISHED BUSINESS

5. Information: SacRT Forward Update/Marketing & Communications Plan (L. Ham/D. Selenis)

6. Approving Fixed Route, ADA Paratransit/Dial-A-Ride, Maintenance Operations Contract and the Second Amendment to the Service Agreement for the City of Elk Grove (L. Ham)
 - A. Resolution: Approving the Fixed Route, ADA Paratransit/Dial-A-Ride, and Maintenance Operations Contract for Service with the City of Elk Grove; and
 - B. Resolution: Conditionally Approving the Second Amendment to the Service Agreement with the City of Elk Grove
7. Information: Update on the Potential Use of Property at the Florin Road Light Rail Station for a Homeless Shelter (B. Bernegger)

PUBLIC HEARING

PUBLIC ADDRESSES BOARD ON MATTERS NOT ON THE AGENDA*

NEW BUSINESS

GENERAL MANAGER'S REPORT

8. General Manager's Report
 - a. SacRT Meeting Calendar

REPORTS, IDEAS AND QUESTIONS FROM DIRECTORS, AND COMMUNICATIONS

CONTINUATION OF PUBLIC ADDRESSES BOARD ON MATTERS NOT ON THE AGENDA (If Necessary)

ANNOUNCEMENT OF CLOSED SESSION ITEMS

RECESS TO CLOSED SESSION

CLOSED SESSION

- A. Conference with Legal Counsel
Pursuant to Gov. Code Section 54956.9(b)
Anticipated Litigation
One Case

RECONVENE IN OPEN SESSION

CLOSED SESSION REPORT

ADJOURN

*NOTICE TO THE PUBLIC

It is the policy of the Board of Directors of the Sacramento Regional Transit District to encourage participation in the meetings of the Board of Directors. At each open meeting, members of the public will be provided with an opportunity to directly address the Board on items of interest to the public that are within the subject matter jurisdiction of the Board of Directors. Please fill out a speaker card and give it to the Board Clerk if you wish to address the Board. Speaker cards are provided on the table at the back of the auditorium.

Public comment may be given on any agenda item as it is called and will be limited by the Chair to 3 minutes or less per speaker. Speakers using a translator will be provided twice the allotted time. When it appears there are several members of the public wishing to address the Board on a specific item, at the outset of the item the Chair of the Board will announce the maximum amount of time that will be allowed for public comment.

Matters under the jurisdiction of the Board and not on the posted agenda may be addressed under the Item "Public addresses the Board on matters not on the agenda." Up to 30 minutes will be allotted for this purpose. The Board limits public comment on matters not on the agenda to 3 minutes per person and not more than 15 minutes for a particular subject. If public comment has reached the 30 minute time limit, and not all public comment has been received, public comment will resume after other business has been conducted as set forth on the agenda. The Board will not act upon or discuss an item that is not listed on the agenda except as provided under Section 3.1.3.6.

This agenda may be amended up to 72 hours prior to the meeting being held. An Agenda, in final form, is located by the front door of Regional Transit's building at 1400 29th Street, Sacramento, California, and is posted on the SacRT website.

The Regional Transit Board of Directors Meeting is being videotaped. A replay of this meeting can be seen on Metrocable Channel 14 and will be webcast at www.sacmetrochannel14.com on March 13th @ 2:00 p.m. and replayed on March 14th @ 9:00 a.m.

Any person(s) requiring accessible formats of the agenda or assisted listening devices/sign language interpreters should contact the Clerk of the Board at 916/556-0456 or TDD 916/483-4327 at least 72 business hours in advance of the Board Meeting.

Copies of staff reports or other written documentation relating to each item of business referred to on the agenda are on SacRT's website, on file with the Clerk to the Board of Directors of the Sacramento Regional Transit District, and are available for public inspection at 1400 29th Street, Sacramento, California. Any person who has any questions concerning any agenda item may call the Clerk to the Board of Sacramento Regional Transit District.

**SACRAMENTO REGIONAL TRANSIT DISTRICT
BOARD OF DIRECTORS
BOARD MEETING
February 25, 2019**

ROLL CALL: Roll Call was taken at 5:33 p.m. PRESENT: Directors Budge, Hansen, Harris, Howell, Hume, Jennings, Miller, Schenirer, Serna and Chair Kennedy. Director Nottoli arrived at 5:48 p.m.

PLEDGE OF ALLEGIANCE

CONSENT CALENDAR

1. Motion: Approval of the Action Summary of January 28, 2019
2. Resolution: Approving the Second Amendment to the Temporary Employment Contract with Leslyn Syren for Attorney III (O. Sanchez-Ochoa/L. Ham)
3. Purchase of Twelve E2 Buses to Operate Service Between UC Davis Campus and the UC Davis Medical Center and Amend the Capital Budget (A. Kennedy/A. Carrasco)
 - A. Resolution: Delegating Authority to the General Manager/CEO to Award a Contract for Purchase of 12 40-Foot Catalyst E2 Buses to Proterra, Inc., and
 - B. Resolution: Approving the Fourth Amendment to the Fiscal Year 2019 Capital Budget
4. Resolution: Approving Amendments to the Fiscal Year 2019 Operating Budget (D. Goldman/B. Bernegger)

ACTION: APPROVED - Director Howell moved; Director Jennings seconded approval of the consent calendar as written. Motion was carried by voice vote. Absent: Director Nottoli

INTRODUCTION OF SPECIAL GUESTS

UNFINISHED BUSINESS

PUBLIC HEARING

PUBLIC ADDRESSES BOARD ON MATTERS NOT ON THE AGENDA

Speakers:

Mike Barnbaum - Mr. Barnbaum provided information on other jurisdictions meetings.

Jeffery Tardaguila – Mr. Tardaguila hopes that the Board is reading the MAC newsletter; has gone through 5 Connect Cards that were not working; need to add another Connect Card terminal at Sacramento Valley Station; and took the longest trip on Paratransit ever in his life.

Robert Coplin – Mr. Coplin, “speaking as part of the Sacramento Mechanics Union, because RT cannot fix the problems they have, only you people up here can with more housing. People cannot afford to go anywhere, they’re not going to ride RT. I hope you know this. What Sacramento County needs more housing and a reason why the people ride the RT bus system, and I don’t see it right now. The whole County has failed with the rising rents. You’re not getting the job done.” The crossing arms were down 3 – 4 and people had to wait at 19th Street last week.

NEW BUSINESS

5. Resolution: Approving the Renaming of the 39th Street Light Rail Station to the 39th Street/UC Davis Health Station (D. Selenis)

ACTION: APPROVED - Director Harris moved; Director Jennings seconded approval of the item as written. Motion was carried by voice vote.

6. Agreement with the City of Elk Grove for Transit Services (L. Ham)
 - A. Resolution: Approving the Fixed Route, ADA Paratransit/Dial-A-Ride, and Maintenance Operations Contract for Service with the City of Elk Grove; and
 - B. Resolution: Conditionally Approving the Second Amendment to the Service Agreement with the City of Elk Grove

Speaker: Mike Costa

Director Hume questioned Mr. Costa on how Elk Grove staff felt about having a 3 year term with 1 year extensions as opposed to a 5-year term. Mr. Costa said staff would have to look at this option. He indicated that a benefit of the contract from the beginning (18 months ago) was the cost comparison of SacRT vs. MV’s contract. The 5 year contract afforded the City of Elk Grove (Elk Grove) some benefits with some cost savings over MV. If the contract were to be reopened earlier than the 5 years, Elk Grove would have to look at what type of costs savings were available if SacRT wanted to renegotiate compensation or costs prior to those 5 years. Director Hume also asked about the termination clause. Mr. Costa indicated that the benefit in the termination clause is if SacRT were to terminate the contract, Elk Grove would have to, in order to maintain its transit services, go out and

procure a contract that could take upwards of 9 months minimum. If that option would be considered, there would have to be some sort of negotiation about notification and giving Elk Grove enough time to be able to procure a new contractor before SacRT were to leave the property and terminate the services.

Director Hansen asked whether the buses would be branded as SacRT. Director Hansen indicated that the staff positions seemed duplicative. Ms. Ham indicated that the positions would be dedicated to Elk Grove operations sited in Elk Grove at the corporation yard. There are some similar titles such as Superintendent and Dispatcher. The other positions would be duplicate titles but would need to be assigned in Elk Grove locally. Director Hansen indicated that the liquidated damages provision seems unusual for any agency like SacRT to enter into. Director Hansen wanted to know whether SacRT has even entered into a contract that allowed another agency to penalize SacRT in this way. Ms. Ham and Olga Sanchez-Ochoa, Deputy Chief Counsel indicated that neither of them during their tenure with SacRT had that happened. Director Hansen also questioned the \$350,000 per year contribution.

Director Hansen believes that staff should negotiate a stronger termination provision. Ms. Ham indicated that an option that staff could discuss as part of the termination provision is a potential for a reopener associated with cost. Director Hansen does not believe that the contract represents concentration, but instead it represents SacRT stepping into the shoes of MV under a contract which is not every fair, and does not believe that the Board should delegate to the General Manager/CEO the authority to execute a contract until the Board sees a final terms especially given the \$2.25 million in potential revenue loss over 5 years. The liquidated damages do not feel fair as a partner especially when they are making all the rules. Director Hansen indicated that he could not support this item until he had answers to his questions because SacRT has made significant cuts to its service.

Mr. Li indicated that he wanted to sit down with Directors Hansen and Hume, and Tiffani Fink of Paratransit Inc. to talk about Paratransit Service issues. He feels that staff has a way to move forward. In terms of the \$350,000, staff has followed the practice that was done with the Cities of Citrus Heights and Folsom. Mr. Li indicated that the contract amount should be able to cover the costs. The payment is for Elk Grove to enjoy the light rail service at Cosumnes River College and allows Elk Grove to sit on the SacRT Board. SacRT would like to negotiate a 9 month termination for convenience clause.

Laura Ham indicated that there is an opportunity to address and resolve liquidated damages through dispute resolution.

Director Hansen requested that the buses have some SacRT branding on them. Mr. Li indicated that he will ask Elk Grove to add the SacRT branding on the buses.

Director Nottoli asked for the cost in the current negotiated contract for the facilities that SacRT would be leasing. Laura Ham indicated \$1.00. Director Nottoli suggested a 270 day termination for convenience clause. He would like staff to find a way to balance out the startup costs fitting within the overall costs for the first year.

Director Howell asked whether MV Transportation is a for-profit company. Ms. Ham indicated that they are. Ms. Howell has a problem with the liquidated damages issue. Most of the damages could occur for a number of reasons beyond SacRT's control. It is not normal to have liquidated damages for a public agency. Mr. Li indicated that language was built into the contract for issues "out of SacRT's control." Director Howell also has a problem with the \$350,000 payment.

Director Hume indicated that Elk Grove citizens are leary and have concerns that commuter service is going away, everything is being routed to light rail, and concerned that when decisions have to be made that Elk Grove routes will be on the table first as they were previously, and it is important to remember why Elk Grove wanted to provide "better" transit service. Elk Grove would like to "dip their foot in the pool before we jump in to annexation." The liquidated damages maintain a little bit of that "carrot and the stick" and that SacRT's maintains the quality that the Elk Grove ridership has come to expect. He does not believe that use of the word "subsidize" is not a fair assertion. Director Hume would like to have the annexation discussion before he departs the SacRT Board and Elk Grove City Council.

Director Schenirer agrees with a 9 month cancelation clause and he understands that there is trepidation among Elk Grove leadership and the riders about service over time. Director Schenirer asked if some triggers could be set on liquidated damages so that the contract is performance based where the contract gets more equity over the 5 year period. Director Schenirer moved the item with the direction for staff to come back making the contract so that SacRT can get to the annexation conversation sooner rather than later, if SacRT is performing at the level it thinks it can within the contract, keeping the overall parameters of the contract the same, but look at what we can do to improve it over time.

Chair Kennedy established a sub-committee of the Board consisting of Vice Chair Hansen (chairing the committee), and Directors Hume, Nottoli and Schenirer.

Director Hansen seconded and clarified the motion allowing the negotiations to go forward but that the final contract comes back to the Board for approval. Director Schenirer concurred with the clarification.

Director Nottoli noted the time sensitivity of the getting the sub-committee together.

ACTION: APPROVED - Director Schenirer moved; Director Hansen seconded a motion requesting that the General Manager/CEO continue to negotiate with the City of Elk Grove on both the Fixed Route, ADA Paratransit/Dial-A-Ride, and Maintenance Operations Contract for Service and the Second Amendment to the Service Agreement, and return to the Board with the modified agreements at a future Board meeting. Additionally, Chair Kennedy created a subcommittee of Vice Chair Hansen, Directors Nottoli, Schenirer and Hume, to assist the General Manager/CEO to assist with working on the terms of the agreements. Motion was carried by voice vote.

7. SacRT Forward New Network, Service and Title VI Analysis (J. Boyle/L. Ham)

- A. Resolution: Approving a Title VI Service Change Equity Analysis for Weekend Light Rail Frequency Improvements and the SacRT Forward Plan; and
- B. Resolution: Approving Weekend Light Rail Frequency Improvements That Took Effect Temporarily on January 6, 2019; and
- C. Resolution: Approving the SacRT Forward New Network Plan

Director Serna wanted to know the plan moving forward to adjust concerns. James Boyle indicated that the Planning Department plans to capture boardings daily, the customer service personnel will be receiving phone calls, and staff plans to monitor this network daily addressing concerns as they are received. The Planning Department plans to report back to the Board monthly and will provide a quarterly service change identifying those things that are not working well, and fix them. Mr. Li indicated that staff plans to monitor reliability, on-time performance, ridership and customer satisfaction. Director Serna requested that concerns are addressed in a timely fashion, or with substantive responses.

Director Nottoli wanted to know what sort of frequency is being proposed for the Gerber SmaRT ride. The SmaRT ride is Monday – Friday, and we are talking with SacRT’s operations and customer service staff about possibility doing Saturday service. Is there any e-tran bus that runs along Calvine to connect the Cosumnes River College light rail station, and if so, on the east side of Highway 99, certainly for Elk Grove service area, but for the area coming from Bradshaw west or Elk Grove-Florin West, are there some opportunities to, in coordination with what is proposed here, to improve service for a broader ridership? James Boyle indicated that the Planning Department will reach out to partnership, like Elk Grove, and would meet with them and talk about the new network, to look at ways to coordinate better with them. Director Nottoli asked if the Route 5 will run throughout the year. James Drake indicated that it is planned to run year round, and will be complemented by the SmaRT ride. Director Nottoli wanted to know what the dotted line indicates on La Riviera/Folsom to Watt/Manlove light rail station map (Route 80/84). James Boyle indicated that the dotted line indicates that the Route 84 would stay on Watt Avenue on the weekends and passengers would have to walk from La Riviera to catch the Route 84.

Director Hansen suggested that both public housing communities should be included in the Downtown/East Sacramento SmaRT ride area as only 1 on the communities (Marina Vista) is included. He noted that in the Downtown zone, the hospital (UC Davis Medical Center) is cut out, and wanted to know if that was intentional.

Director Budge noted that the parents from the San Joan Unified School District sent a letter providing incredible statistics about the transit dependency of students as well the letters about Route 5 and Route 19. Director Budge is happy that service to the VA

Hospital (Route 75) and the VA Clinic (Route 26). She is not certain how staff came to the conclusion that the job centers, seniors or transit dependent are being served (Slide 44). Director Budge wanted to know why SacRT is abandoning the philosophy of the relationship between buses and light rail (i.e. Sunrise Station and Folsom Boulevard).

Chair Kennedy noted that he has attended a number of community meetings and the James Boyle and James Drake have made numerous changes to accommodate concerns of the community, and thanked both staff members.

Speakers:	Barbara Stanton	Nick Bryant	Arthur Ketterling
	Helen O'Connell	Trudy Ross	Leslie Thom
	Bonnie Lindemann*	Tracey Schaal	Dan Allison
	Carol Nelson	Mike Barnbaum	Jeffery Tardaguila
	Deborah Wells	Robert Coplin	Doug Dieslam
	Dean Fairbanks	Steven Bourasa	Russell Rawlings
	Gale Morgan	Zach Miller	Joyce Adams Watkins
	Mary Beth Barber	Bruce Griesenbeck	Sharla Smith

Mr. Li noted that staff has discussed the potential additional services for the San Juan USD and noted that staff has planned for adding 4 school peak time routes specifically for the San Juan USD.

Director Serna wants to know how staff communicates with agencies such as the Society for the Blind to offer additional services to help sight impaired ridership relearn new routes. Director Serna would like the issues concerning Route 13 be reconsidered since there are so few routes in the Natomas area. He would also like the Route 68 rerouted back to its current route to address the connectivity of the Fruitridge Community Collaborative in the South Oak Park/ Fruitridge neighborhood. James Boyle noted that staff has worked closely with the Mobility Advisory Council (MAC) and SacRT's Accessible Services Department to make sure that the visual impaired community knows exactly what the route changes are and what is being proposed. Staff can provide a very detailed route by route and turn by turn description. Laura Ham noted that the Accessible Services Department supports the travel training programs in the community (The Society for the Blind, Paratransit Inc., National Federation and the California Council of the Blind are represented on the Mobility Advisory Council). SacRT supports and provides passes for the Society for the Blind, Paratransit, Inc. and other programs. Director Serna wants staff to coordinate, or work closely with the Society for the Blind, to provide some additional level of service that is requested to help those in need. James Boyle understands there is a concern with Route 13 and staff will look again at adding some afternoon trips so that both morning and afternoon trips are covered. James Drake agreed that it would be a minor change to keep the Route 68 as is.

Director Nottoli recognized that staff made a tough choice with all the routes, but wanted to address the Route 80/84 again. Director Nottoli requested that staff look at some service on the weekend south of Folsom Boulevard, and provide the ridership numbers. The Sunrise Station was supposed to be a major hub station and if the station is being

underutilized, what is the long term plan for that station. Director Nottoli noted that staff is modifying and trying to have more frequent service, but we are really not reaching any new areas in the County, and there is a growth area that is being levied a fee annually in the Vineyard area, certainly would not cover the cost of the bus, but there is nothing in this plan or that he sees on the horizon to look at how we might build ridership in that area and get people to a light rail station or to backbone service. Director Nottoli is concerned at all of the concerns of the Route 2 have not been addressed. James Boyle noted that the County has made a large investment on Watt Avenue with bus lanes and signal priority for SacRT to use, so staff did not want to disregard that infrastructure so that is why they left the Route 80/84 on Watt Avenue. Director Nottoli indicated that he will take the people's preference over the infrastructure.

Director Budge noted that Rancho Cordova (RC) is in a difficult position because RC has not had a lot of service. She is concerned about the Sunrise Station not being utilized. RC has made investments in transit and was one of the 3 new cities that were required to join SacRT in the LAFCO agreement. Director Budge indicated that the current Cordovan are currently being funded by the transit tax that the homeowner's pay and that, on a per capita basis, the City of Rancho Cordova pays more than the City of Sacramento for transit services that they do not have, and when buying their investment in the Cordovan routes, they are truly paying out of pocket for the little bit of transit service they do have.

James Boyle reminded the Board that SacRT has received a grant from Caltrans to look at BRT, BRT corridors and service in SacRT's service area. The Sunrise Station corridor is one of those corridors that staff will be looking at for this type of service.

Director Howell indicated that the changes that are being proposed are improvements and that tweaks may be required. Director Howell supports the changes.

Director Harris is in support of moving forward and make adjustments as needed.

Director Jennings asked for a description of how tweaks will be made and how the public will be notified, and how the public can suggest change. James Boyle indicated that staff will be communicating with the public in many ways and capturing all the comments and suggestions throughout the process.

Director Miller asked staff to continue with outreach, and supports the next step to improvement.

Chair Kennedy commended staff on their work on this project.

ACTION: Failed: Subsequent Motion: Director Serna moved; Director Budge seconded a motion to delay approval of the implementation of the SacRT Forward network requesting further refinements to some of the routes. Ayes: Directors Budge, Nottoli, Serna. Noes: Directors Hansen, Harris, Howell, Hume, Jennings, Miller, Chair Kennedy. Absent: Director Schenirer.

ACTION: APPROVED - Director Hansen moved; Chair Kennedy seconded approval of the items as written. Ayes: Directors Hansen, Harris, Howell, Hume, Jennings, Miller, Serna and Chair Kennedy. Noes: Directors Budge and Nottoli. Absent: Director Schenirer. Motion was carried by roll call vote.

GENERAL MANAGER’S REPORT

- 8. General Manager’s Report
 - a. SacRT Meeting Calendar

The General Manager/CEO deferred his General Manager’s Report.

REPORTS, IDEAS AND QUESTIONS FROM DIRECTORS, AND COMMUNICATIONS

- 9. San Joaquin Joint Powers Authority Meeting – January 25, 2019 (Hume)

No additional comments were provided.

- 10. Paratransit Inc. Board of Directors Meeting – January 30, 2019 (Hume)

No additional comments were provided.

- 11. Capitol Corridor Joint Powers Authority Meeting – February 13, 2019 (Kennedy/Miller)

No additional comments were provided.

CONTINUATION OF PUBLIC ADDRESSES BOARD ON MATTERS NOT ON THE AGENDA (If Necessary)

ANNOUNCEMENT OF CLOSED SESSION ITEMS

The Clerk announced that Closed Session is being canceled.

RECESS TO CLOSED SESSION

CLOSED SESSION

- A. Conference with Legal Counsel
 - Pursuant to Gov. Code Section 54956.9(b)
 - Anticipated Litigation
 - One Case

RECONVENE IN OPEN SESSION

CLOSED SESSION REPORT

ADJOURN

*Handout

As there was no further business to be conducted, the meeting was adjourned at 9:00 p.m.

PATRICK KENNEDY, Chair

A T T E S T:

HENRY LI, Secretary

By: _____
Cindy Brooks, Assistant Secretary

REGIONAL TRANSIT ISSUE PAPER

Agenda Item No.	Board Meeting Date	Open/Closed Session	Information/Action Item	Issue Date
2	03/11/19	Open	Action	02/26/19

Subject: Approving Delegation of Authority to the General Manager/CEO to Award a Contract for the Purchase of LRV Tire Kits.

ISSUE

Whether or not to delegate authority to the General Manager/CEO to award a Contract for the purchase of Light Rail Vehicle (LRV) Tire Kits.

RECOMMENDED ACTION

Adopt Resolution No. 19-03-____, Delegating Authority to the General Manager/CEO to Award a Contract for the Purchase of LRV Tire Kits.

FISCAL IMPACT

Budgeted:	Yes	This FY:	\$	424,992.00
Budget Source:	Operation	Next FY:	\$	888,288.00
Funding Source:	Federal and Local	Annualized:	\$	
Cost Cntr/GL Acct(s) or Capital Project #:	GL 121000 (Inventory)	Total Amount:	\$	1,313,280.00*
Total Budget:	\$ 1,313,280.00*			

* does not include sales tax

DISCUSSION

Staff has identified a need to purchase 456 LRV Tire Kits. These tire kits will be used on both Siemens and CAF LRVs and are standard inventory items. LRV tire kits consist of a steel outer rim, electrical shunts and hardware. These tires are pressed on to a light rail vehicle axle per a SacRT-required profile for transporting an LRV over SacRT's rail system. The term "kit" is used to describe the component parts.

LRV steel tires have a life cycle based on the amount of miles run on each tire. When a tire reaches the end of its life cycle, it can no longer be used for safety reasons, much like a rubber automobile tire.

Staff posted an Invitation for Bid (ITB) on January 11, 2019 with a bid due date of February 13, 2019. Bids were received from Siemens Mobility Inc. and Penn Machine Company. Both bidders provided an alternate delivery schedule that did not meet the required delivery schedule listed in Section 5.1 of the Invitation for Bid. As a result, both bidders were determined non-responsive and were rejected. The change made by both bidders was to ship monthly, in smaller quantities, which will meet SacRT's Maintenance needs.

Approved:

Presented:

Final 03/16/19

General Manager/CEO

Vice President, Maintenance

J:\Board Meeting Documents\2019\04 March 11, 2019\2018030 LRV Tire Issue Paper 2.19.19.doc

Agenda Item No.	Board Meeting Date	Open/Closed Session	Information/Action Item	Issue Date
2	03/11/19	Open	Action	02/26/19

Subject: Approving Delegation of Authority to the General Manager/CEO to Award a Contract for the Purchase of LRV Tire Kits.

Accordingly, Staff has revised the delivery schedule and will re-post the IFB. To expedite award of the contract, staff requests the Board delegate authority for the General Manager/CEO to award the contract once the lowest responsive and responsible bidder is determined from the bids received at the conclusion of the bid period. A sealed low bid procurement for LRV tire kits will result in a firm fixed price contract and the selection of the successful bidder made to the lowest responsible and responsive bidder.

Staff recommends the Board to delegate authority to the General Manager/CEO to award a contract for the purchase of light rail vehicle tire kits to the lowest priced responsive and responsible Bidder.

RESOLUTION NO. 19-03-_____

Adopted by the Board of Directors of the Sacramento Regional Transit District on this date:

March 11, 2019

**DELEGATING AUTHORITY TO THE GENERAL MANAGER/CEO TO AWARD A
CONTRACT FOR THE PURCHASE OF LRV TIRE KITS**

BE IT HEREBY RESOLVED BY THE BOARD OF DIRECTORS OF THE
SACRAMENTO REGIONAL TRANSIT DISTRICT AS FOLLOWS:

THAT, the Board hereby delegates authority to the General Manager/CEO to award and execute a Contract for Purchase of Light Rail Vehicle Tire Kits to the lowest priced responsive and responsible Bidder after competitive bidding for an amount not to exceed \$1,313,380.00 excluding sales tax.

PATRICK KENNEDY, Chair

A T T E S T:

HENRY LI, Secretary

By: _____
Cindy Brooks, Assistant Secretary

REGIONAL TRANSIT ISSUE PAPER

Agenda Item No.	Board Meeting Date	Open/Closed Session	Information/Action Item	Issue Date
3	3/11/19	Open	Action	3/04/19

Subject: Approving the License Agreement with the City of Sacramento to manage the parking lot located at 510 12th Street and 1122 E Street, Sacramento, California

ISSUE

Whether to approve the License Agreement with the City of Sacramento for the parking lot located at 510 12th Street and 1122 E Street in Sacramento, CA.

RECOMMENDED ACTION

Adopt Resolution No. 19-03-_____, Approving a License Agreement with the City of Sacramento to manage Sacramento Regional Transit District's (SacRT) Property Located at 510 12th Street and 1122 E Street, Sacramento, CA.

FISCAL IMPACT

Approval of the License Agreement

DISCUSSION

Sacramento Regional Transit District (SacRT) purchased land at 510 12th Street and 1122 E Street, Sacramento CA (APN: 002-0116-007, 002-0116-009) during construction of the downtown starter line in order to install and retain access to light rail equipment. In 2006, SacRT found a tenant to lease the parking lot for private use at this location. Subsequently, SacRT learned that the original intent of the parking lot was to provide public parking intended to replace street parking lost because of the installation of the Light Rail in downtown. Therefore, SacRT terminated the lease agreement with the existing tenant and has requested assistance from the City of Sacramento (City) to conduct upgrades to improve the safety and security of the lot while also allowing public use of the parking lot and fair value for the lease.

SacRT would like to enter into a five-year agreement with an attentive date of April 1, 2019, with the City to monitor the parking lot for the use of public parking. The City would be responsible for upgrading improvements to the parking lot, including ADA stalls and performing ongoing maintenance. The City will provide a parking enforcement presence to deter unauthorized parking and manage the lot that will provide parking to the public.

Staff recommends approval the of the License Agreement with the City of Sacramento.

Approved:

Presented:

Final 03/16/19

General Manager/CEO

VP, Finance/Chief Financial Officer

J:\Board Meeting Documents\2019\04 March 11, 2019\City of Sacramento License Agreement.doc

RESOLUTION NO. 19-03-_____

Adopted by the Board of Directors of the Sacramento Regional Transit District on this date:

March 11, 2019

**APPROVING A LICENSE AGREEMENT WITH THE CITY OF SACRAMENTO TO
MANAGE SACRAMENTO REGIONAL TRANSIT DISTRICT'S (SACRT) PROPERTY
LOCATED AT 510 12th STREET AND 1122 E STREET, SACRAMENTO, CA.**

BE IT HEREBY RESOLVED BY THE BOARD OF DIRECTORS OF THE
SACRAMENTO REGIONAL TRANSIT DISTRICT AS FOLLOWS:

THAT, the License Agreement between the Sacramento Regional Transit District, therein referred to as "Licensor" or "SacRT" and the City of Sacramento, therein referred to as "Licensee" whereby Licensor grants an exclusive license for the purpose of occupying and maintaining the parking lots, is hereby approved.

THAT, the General Manager/CEO is hereby authorized and directed to execute said License Agreement.

PATRICK KENNEDY, Chair

A T T E S T:

HENRY LI, Secretary

By: _____
Cindy Brooks, Assistant Secretary

REGIONAL TRANSIT ISSUE PAPER

Agenda Item No.	Board Meeting Date	Open/Closed Session	Information/Action Item	Issue Date
4	03/11/19	Open	Action	03/06/19

Subject: Travel Outside the United States for Patrick Kennedy, Chair. SacRT Board of Directors

ISSUE

Whether or not to authorize travel outside the United States for Patrick Kennedy, Chair, SacRT Board of Directors, to represent Sacramento's transportation industry to assist the Mayor of Sacramento to lead a regional trade mission to China focused on smart cities.

RECOMMENDED ACTION

Adopt Resolution No. 19-03-___, Authorizing Travel Outside the United State for Patrick Kennedy, Chair, SacRT Board of Directors, to Represent Sacramento's Transportation Industry to Assist the Mayor of Sacramento to Lead a Regional Trade Mission to China Focused on Smart Cities.

FISCAL IMPACT

Budgeted:		This FY:	\$	3,000.00
Budget Source:	Operating	Next FY:	\$	
Funding Source:	Local	Annualized:	\$	
Cost Cntr/GL Acct(s) or Capital Project #:	Cost Center 14 GL 690006, 690005	Total Amount:	\$	3,000.00
Total Budget:	\$ 3,000.00			

*The budget is very reasonable, and similar to the cost of trips within the United States.

DISCUSSION

SacRT's Chair of the Board, Patrick Kennedy, has been invited to participate in the 2019 regional trade mission to China from March 27 - April 4, 2019.

The trade mission is focused on building bridges between Sacramento and Smart City partners in China. The Mayor of Sacramento has strongly encouraged SacRT to participate and has recruited a robust delegation comprised of business officials, community leaders, elected officials and other stakeholders to attend.

SacRT strives to benefit from participation on the trade mission by:

- Looking for potential investment/funding opportunities
- Briefings on Smart Mobility options such as autonomous and electric vehicles

Approved:

Presented:

Final 03/06/19

General Manager/CEO

Clerk to the Board

J:\Board Meeting Documents\2019\04 March 11, 2019\Travel Outside United States - Kennedy China.doc

REGIONAL TRANSIT ISSUE PAPER

Agenda Item No.	Board Meeting Date	Open/Closed Session	Information/Action Item	Issue Date
4	03/11/19	Open	Action	03/06/19

Subject: Travel Outside the United States for Patrick Kennedy, Chair. SacRT Board of Directors

- Building direct relationships and network between Sacramento and Smart City Partners in China
- Attending meeting with counterparts in China to learn the best practices of the transit industry
- Learn about the latest advancement in technology that affect transportation and the future of mobility
- Meetings with officials, business owners and transit riders
- Examine opportunities for partnerships and collaborations
- Learn from transit peers about experiences with new technologies and how they are re-envisioning mobility

Pursuant to Title IX of the SacRT Administrative Code - Travel Authorization, travel outside the United States must be approved by the Board in advance.

The travel request covers the cost of the program, but does not cover any costs associated with the personal day in Hong Kong.

Staff recommends approval for Patrick Kennedy, Chair, SacRT Board of Directors, to travel to China as part of the Building Bridges trade delegation from March 27 - April 4, 2019.

RESOLUTION NO. 19-03-_____

Adopted by the Board of Directors of the Sacramento Regional Transit District on this date:

March 11, 2019

AUTHORIZING TRAVEL OUTSIDE THE UNITED STATE FOR PATRICK KENNEDY, CHAIR, SACRT BOARD OF DIRECTORS, TO REPRESENT SACRAMENTO'S TRANSPORTATION INDUSTRY TO ASSIST THE MAYOR OF SACRAMENTO TO LEAD A REGIONAL TRADE MISSION TO CHINA FOCUSED ON SMART CITIES

BE IT HEREBY RESOLVED BY THE BOARD OF DIRECTORS OF THE SACRAMENTO REGIONAL TRANSIT DISTRICT AS FOLLOWS:

THAT, travel outside the United States by Patrick Kennedy for the purpose set out in the attached Travel Request form will serve a Regional Transit business purpose and is hereby approved in accordance with Section 9.211 of Title IX of the Regional Transit Administrative Code.

THAT, the Vice Chair is hereby authorized to sign the attached Travel Request form.

PATRICK KENNEDY, Chair

A T T E S T:

HENRY LI, Secretary

By: _____
Cindy Brooks, Assistant Secretary

Sacramento Regional Transit District

Request For Travel

1. Originating Department: Board Support

Purpose: (Description) Represent Sacramento's Transportation Industry to Assist the Mayor of Sacramento to Lead a Regional Trade Mission to China Focused on Smart Cities

2. Function to Attend: Regional Trade Mission to China
(Title of seminar, conference, peer review, etc.)

3. Destination: In U.S.: _____
(Location)
 Outside U.S.: Beijing, Chongquig, Guangzhou, Hong Kong
(Location)

4. Dates: a) Travel Mar-27-2019 (Wed) to Apr-04-2019 (Thu)
b) Meeting Mar-27-2019 (Wed) to Apr-04-2019 (Thu)

5. Estimated Trip Costs:

Summary of Costs	Meals	Lodging	Transportation	Other Expenses	Total Costs
				\$ 3,000.00	\$ 3,000.00

6. Travel Advance: Based on estimated of total costs (above) \$ 3,000.00 x 90% = \$ 2,700.00

7. Person Attending: Name Patrick Kennedy
Signature _____ Date _____

(Signature of person requesting travel authorization constitutes declaration that personal business or other non-District purpose pursued on trip, if any, shall not interfere with scheduled meeting or other purpose of District travel.)

8. General Ledger Number: 690006/690005-14

9. Funds budgeted and unencumbered: W. Mlotha 3-5-19
Financial Analyst Date

10. Senior Staff Review: _____
Senior Staff Member Date

11. Approval Required by: (check one)

- a. **Board** (travel outside of the U.S.)
- b. **Chair** (travel by Board Member, General Manager, or Chief Legal Counsel within the U.S. or any travel outside the U.S. that could be not be anticipated in advance of a board meeting) or Vice Chair for Chair
- c. **General Manager** (budgeted and unbudgeted travel within the U.S. by staff)

Approval: _____
Signature of Authorized Officer Date

REGIONAL TRANSIT ISSUE PAPER

Agenda Item No.	Board Meeting Date	Open/Closed Session	Information/Action Item	Issue Date
4A	03/11/19	Open	Action	03/08/19

Subject: Whether or not to Amend the Contract with Urban Transportation Associates for the Purchase of Additional Automated Passenger Counters

ISSUE

Whether or not to Amend the Contract with Urban Transportation Associates for the Purchase of Additional Automated Passenger Counters for SacRT's Siemens Light Rail Fleet.

RECOMMENDED ACTION

Adopt Resolution No 19-03-_____, Approving the Second Amendment to the Contract with Urban Transportation Associates for the Purchase of Additional Automated Passenger Counters.

FISCAL IMPACT

Budgeted:	Yes	This FY:	\$277,844
Budget Source:	Capital	Next FY:	\$
Funding Source:	Calif. STA, Revenue Bonds	Annualized:	\$277,844
Cost Cntr/GL Acct(s) or Capital Project #:	R355	Total Amount:	\$277,844*
Total Budget:	\$1,310,000		

*plus applicable sales tax and shipping

DISCUSSION

On February 26, 2018, the Board delegated authority to the General Manager/CEO to release a Request for Proposals and award a Contract for the Purchase of Light Rail Automated Passenger Counters (APCs).

A contract was subsequently awarded to Urban Transportation Associates (UTA) for the purchase and installation APCs for SacRT's CAF and UTDC light rail fleets. As directed in the Request for Proposal, UTA provided SacRT with optional contract pricing to purchase additional equipment and installation services for SacRT's Siemens light rail fleet in the future.

Staff has determined that it is in the best interest of SacRT to equip its' Siemens vehicles with automated counters in order to provide 100% APC coverage of the entire light rail fleet. This will result in better data analytics and reporting accuracy for light rail system ridership.

Staff recommends amending the contract with Urban Transportation Associates and exercising the option for additional rail car equipment installations and increasing the contract by \$277,844 to \$1,257,190, plus applicable sales tax and shipping.

Approved:

Presented:

General Manager/CEO

Director, Information Technology

J:\Board Meeting Documents\2019\04 March 11, 2019\UTA Contract Amendment -Siemens Option rev 2.docx

RESOLUTION NO. 19-03-_____

Adopted by the Board of Directors of the Sacramento Regional Transit District on this date:

March 11, 2019

**APPROVING THE SECOND AMENDMENT TO THE CONTRACT WITH URBAN
TRANSPORTATION ASSOCIATES FOR THE PURCHASE OF ADDITIONAL
AUTOMATED PASSENGER COUNTERS**

BE IT HEREBY RESOLVED BY THE BOARD OF DIRECTORS OF THE
SACRAMENTO REGIONAL TRANSIT DISTRICT AS FOLLOWS:

THAT, the Second Amendment to the Purchase Contract between Sacramento Regional Transit District, therein referred to as "SacRT," and Urban Transportation Associates, therein referred to as "Contractor," whereby the not-to-exceed amount of the Contract is increased by \$277,844, from \$979,346 to \$1,257,190 plus applicable sales tax and shipping for the purchase and installation of additional automated passenger counters, is hereby approved.

THAT, the General Manager/CEO is hereby authorized and directed to execute said Second Amendment.

PATRICK KENNEDY, Chair

A T T E S T:

HENRY LI, Secretary

By: _____
Cindy Brooks, Assistant Secretary

REGIONAL TRANSIT ISSUE PAPER

Agenda Item No.	Board Meeting Date	Open/Closed Session	Information/Action Item	Issue Date
5	03/11/19	Open	Information	03/04/19

Subject: SacRT Forward Network, and the Communications and Marketing Plan

ISSUE

To provide a report to the Board on the SacRT Forward Network and the upcoming Communications and Marketing Plan.

RECOMMENDED ACTION

None as a result of this report.

DISCUSSION

Staff will present an update on the SacRT Forward project.

Approved:

Final 03/06/19

General Manager/CEO

Presented:

VP, Planning and Accountability and VP, Communications and Partnerships

J:\Board Meeting Documents\2019\04 March 11, 2019\SacRT Forward Network & Communications and Marketing Plan Update1.doc



SacRT Forward Update

March 11, 2019 — Agenda Item #5

SacRT Forward

Major Goals Included:

- New Regional Mobility Options
- Develop New Bus Network
- Engage the Public
- Understand Travel Demand Patterns

Public Feedback

Major Common Themes

- More weekend service
- More frequent service
- More late night service
- More places
- 7 day-a-week routes

SacRT Forward Update



SacRT Forward Update

SacRT Forward Highlights

1. Comprehensive Outreach and Marketing Campaign
2. Delay June launch date to September 2019
3. Added four new peak hour service trips for San Juan School District
4. Overall, added 3.5% additional service with \$3 million of SB1 funding

SacRT Forward Update

SacRT Forward Highlights (continued)

5. Added additional service to suburban areas
6. Reassess new network and report monthly
7. Evaluate bus stop spacing and consolidate and/or install new stops by September 2019
8. ADA paratransit service grandparenting – no change to existing service

SacRT Forward Update

Future Growth

- Additional frequency and coverage
- Permanent funding for future SmaRT Ride Service

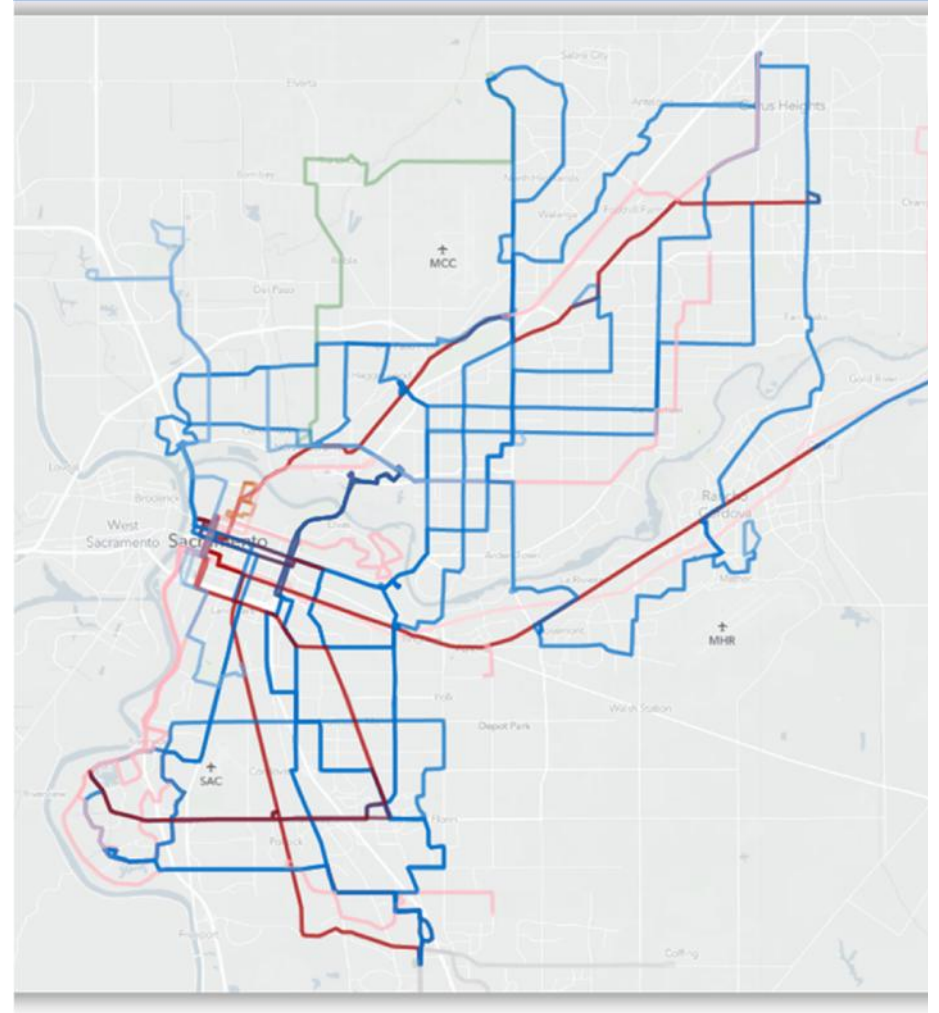

SacRT Forward Update

SacRT = 1/6 Cent Local Funding



San Diego = More Than 1/2 Cent Local Funding



200 Buses

400 Buses

600 Buses

800 Buses

(400% more buses with only 35% more population than SacRT)

Network Design Updates

Route Updates

- **Route 2** – added a 6:07pm trip from Downtown
- **Route 6** – added a 6:25pm trip from Downtown
- **Route 13** – In addition to the improved Route 13, Keep 2 AM and 2 PM trips for commuters, rename to route 113 (peak only). Basically, same alignment as Route 13 runs today (stays on North Market)
- **Route 68** – keep existing alignment on 44th St (Fruitridge Community Collaborative)
- **Route 84** – keep on La Riviera 7 days a week
- **Launch planning effort on Sunrise Boulevard Corridor**

Network Design Updates

Route 113

- Peak only trips
 - 6:23am and 7:23am
 - 4:45pm and 5:23pm
- Route will operate on North Market Drive
- Preserves new and improved Route 13
- Cost \$60,000
- Daily Avg = 100 boardings

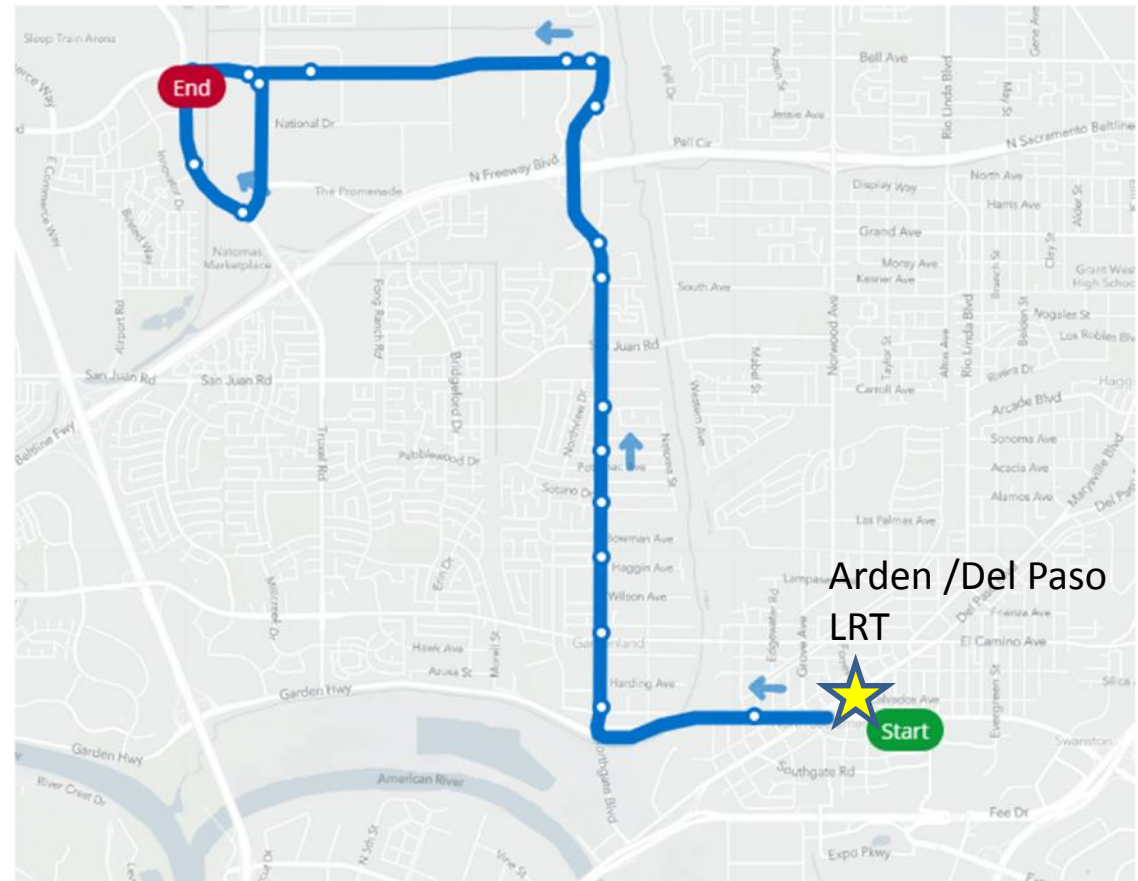

Network Design Updates

- Four new routes for San Juan Unified School District (SJUSD)
- Staff is working with the District, Parent/Teacher Association, and Safe Routes to School coordinators to identify best routes – Meeting held March 6, 2019
- Accessible transit information and pass sales a key issue for SJUSD

Outreach and Marketing Campaign



Focus on Six Sectors



Campaign Elements

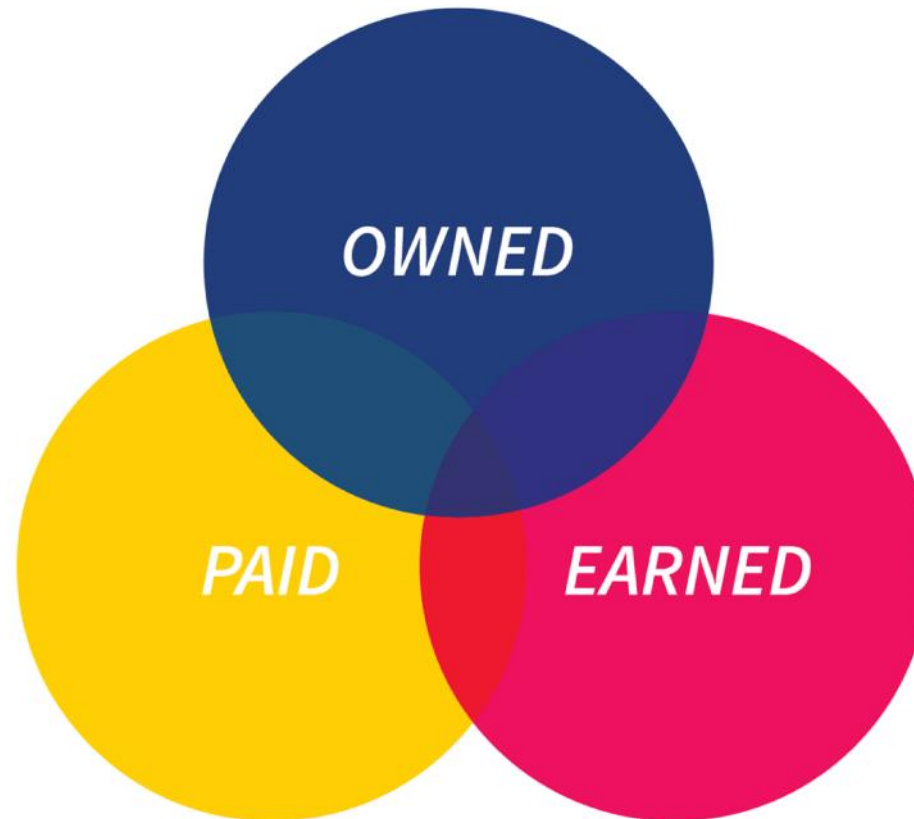

Messaging

Look Forward To ...

- More Frequent Service
- More Weekend Service
- Longer Service Hours
- More Destinations



Outreach and Marketing Campaign

Phase 1: (February 26 – March 31)

- Bus and Light Rail Signage
- News Release
- Updated Website
- Email Blast
- Social Media
- Flyer Distribution
- GM Chat

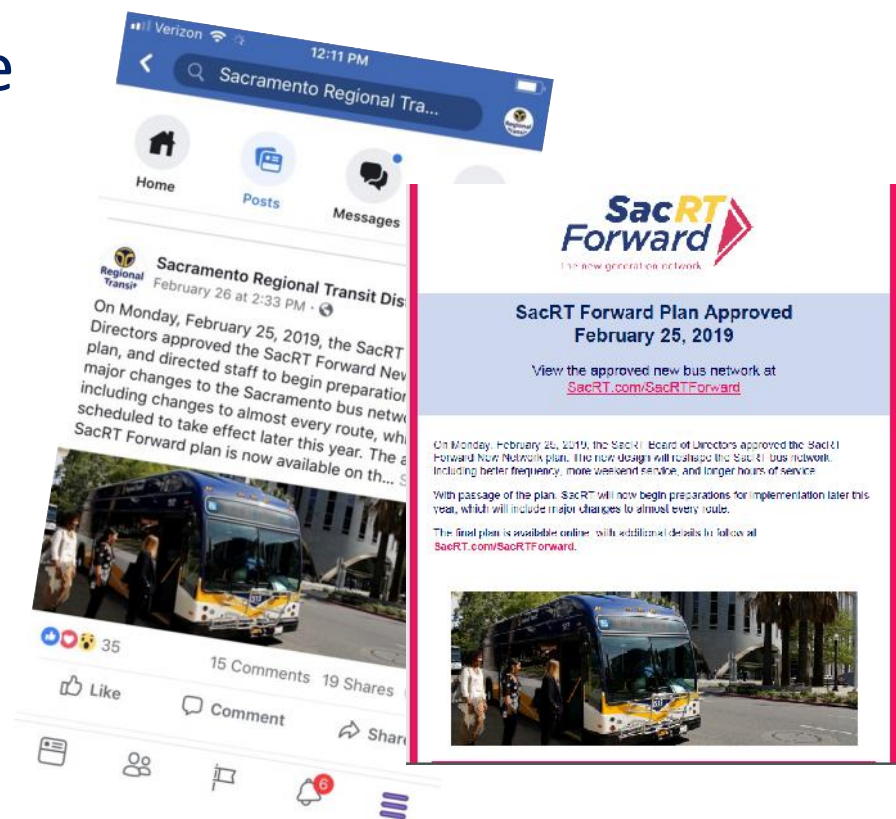

Outreach and Marketing Campaign

Phase 2: (April 1 – June 30)

- Everything in Phase 1
- Bus Boardings
- Push Notifications
- Nextdoor Post
- Service Change Booklets
- Distribute Multi-Language Flyers
- A-Frame Signage
- Sidewalk Advertising
- Electronic Station Signage

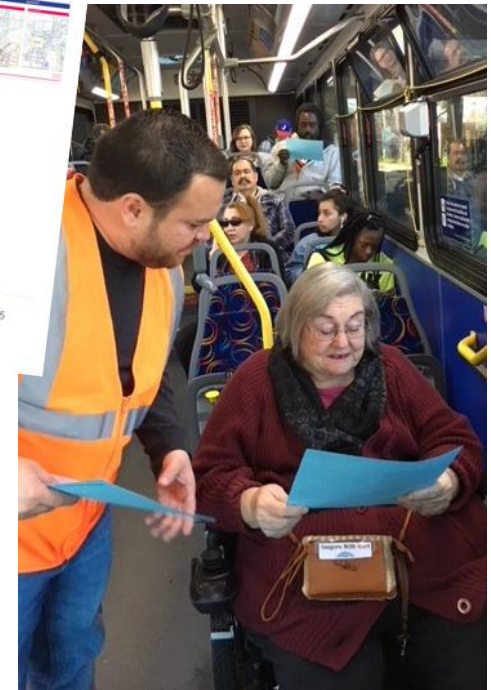
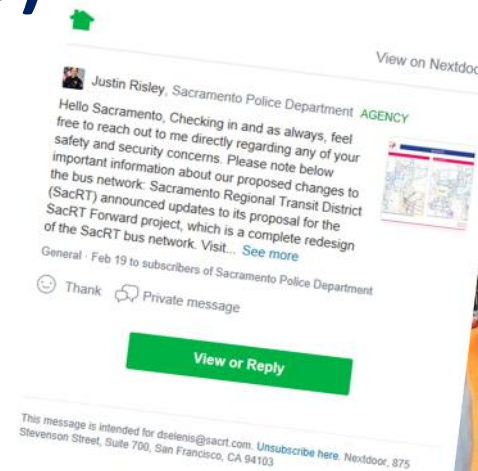

Outreach and Marketing Campaign

Phase 3: (July 1 – September)

- Everything in Phases 1 & 2
- Travel Training for Persons with Disabilities
- How-to-Ride & Rider Testimonial Videos
- New Pocket Schedules
- New System Map
- Media Engagement
- Paid Advertising
- PA Announcements



Outreach and Marketing Campaign

Phase 4: (Launch of New Service & Beyond)

- Everything in Phases 1, 2 & 3
- “SacRT in Your Neighborhood” Online Forum
- Press Conference
- Direct Mail
- Free Ride Days
- Rider Feedback



Take a ride on us!

The Sacramento Regional Transit District (RTD) and the North Yuba County Transit Authority encourage you to leave your car at home and try RTD.

Getting downtown has never been easier. Route 11 travels close by your neighborhood and operates every 30 to 60 minutes on weekdays, and now on Saturdays thanks to recently implemented RT service improvements. Once downtown, connections are easy. Hop on light rail, or another bus route to travel to school, work, shopping or medical appointments.

To get started, simply detach the complimentary pass from this flyer and hand it to the bus operator upon boarding. A Route 11 schedule and map are located on the other side. For trip planning assistance, visit www.sacrt.com and click on the "Online Trip Planner" link, or call one of RTD's knowledgeable Customer Service Representatives at 916-321-BUSS (2877).



New Outreach Concepts

Online Forum “SacRT in Your Neighborhood”



Sidewalk Advertising



SacRT Forward Outreach Bus



Media Engagement

Reporter Ride-A-Longs



News Releases



CONTACT: Davra Sellers
OFFICE: 916-556-0121
CELL: 916-969-8022

FOR IMMEDIATE RELEASE
DATE: February 25, 2019

SacRT Board Approves New Bus Network

SACRAMENTO, CA – The Sacramento Regional Transit District (SacRT) Board of Directors approved a new bus network proposal, which comprehensively redesigns SacRT's bus system.

"We are excited to begin the process of rolling out our new bus network in a few months," said SacRT General Manager (GM) Henry J. "To ensure the success of the new network, SacRT will conduct frequent monitoring of the new bus service to optimize and adjust service where it's needed most."

A draft plan was released for public review on December 10, 2018. Since then, major outreach efforts took place to let riders and stakeholders know about the proposed plan, called SacRT Forward.

Based on the comments received and reviewing ridership and demographic data, staff spent the past few and half months making adjustments to the plan. A revised bus network proposal was released for public review on February 18, 2019, and approved by the SacRT Board of Directors on February 25, 2019. The new service is expected to start in summer 2019.

"We have been actively listening to our riders and the community for the past year and a half to make changes that will best fit their lifestyle and help improve mobility options for the Sacramento region," said SacRT Board Chair and Sacramento County Supervisor Patrick Kennedy. "Travel will be more convenient, regional mobility options have been expanded and

Press Conference



Questions and Suggestions



REGIONAL TRANSIT ISSUE PAPER

Agenda Item No.	Board Meeting Date	Open/Closed Session	Information/Action Item	Issue Date
6	03/11/19	Open	Action	03/06/19

Subject: Agreement with the City of Elk Grove for Transit Services

-ISSUE

Whether to approve the Fixed Route, ADA Paratransit/Dial-A-Ride, and Maintenance Operations Contract for Service and conditionally approve the Second Amendment to the Service Agreement with the City of Elk Grove.

RECOMMENDED ACTION

- A. Adopt Resolution No. 19-03-___, Approving the Fixed Route, ADA Paratransit/Dial-A-Ride, and Maintenance Operations Contract for Service with the City of Elk Grove; and
- B. Adopt Resolution No. 19-03-___, Conditionally Approving the Second Amendment to the Service Agreement with the City of Elk Grove.

FISCAL IMPACT

Budgeted:	Yes	This FY:	\$	452,246*
Budget Source:	Operating	Next FY:	\$	6,757,207
Funding Source:	Elk Grove Contract*	Annualized:	\$	7.16 Million
Cost Cntr/GL Acct(s) or Capital Project #:	Various GLs	Total Amount:	\$	35.8 Million
Total Budget:	\$ Various GLs			

* The Elk Grove contract is anticipated to fund the service during the contract period; however, \$452,246 of unreimbursed startup labor and training costs will be incurred during this Fiscal Year. In addition, as more fully discussed below, the Operations Contract will be a fixed-rate rather than actual cost reimbursement methodology, so there is a risk of unreimbursed costs in future fiscal years.

Background

In January of 2005, the City of Elk Grove (City) assumed responsibility from Sacramento Regional Transit District (SacRT) for the administration and operation of all transit services to, from, and within the City. The service was branded by the City as “e-tran” and included commuter and local routes. In July 2006, the City also began operation of demand-response services and Americans with Disabilities Act (ADA) complementary paratransit services, branded as “e-van.”

In conjunction with the City’s separation from SacRT, the City entered into a Service Agreement with SacRT. The key terms of the Service Agreement include: (1) providing permission for City transit services to operate within SacRT’s service area, (2) establishing a proportionate share payment to SacRT based on the benefits that light rail and other SacRT regional services provide

Approved:

Presented:

General Manager/CEO

VP, Planning and Accountability

Agenda Item No.	Board Meeting Date	Open/Closed Session	Information/Action Item	Issue Date
6	03/11/19	Open	Action	03/06/19

Subject: Agreement with the City of Elk Grove for Transit Services

to City residents, and (3) designating one City representative on the SacRT Board of Directors. The term of the current Service Agreement is July 1, 2017 through June 30, 2020, with an annual proportionate share payment to SacRT of \$350,000. If a contract for SacRT to operate the City’s e-tran and e-van service is approved, payment thereunder to SacRT would be considered to satisfy the proportionate share requirement until the contract is terminated. This change would be reflected in an amended Service Agreement.

The City currently contracts with MV Transportation for the operation of its public transit service and the contract expires on June 30, 2019. In April 2017, SacRT and the City began discussions regarding SacRT operation of the City’s e-tran and e-van services under an intergovernmental agreement. SacRT’s proposal offers the City a number of benefits, including improved service quality, enhanced employee benefits, economies of scale savings, and a greater ability to collaborate on regional transit operations.

After a discussion of the proposed contract terms at the February 25 Board Meeting, the Board requested that the General Manager/CEO re-open negotiations regarding the terms of the contract and created a subcommittee including Vice Chair Hansen, and Directors Hume, Nottoli, and Schenirer to assist with negotiations.

The subcommittee held a meeting on March 4, which included participation of by SacRT and City staff on March 4. SacRT Staff are now returning with the following terms (new or revised terms are noted in italics):

Contract Term and Termination

The proposed Fixed Route, ADA Paratransit/Dial-A-Ride, and Maintenance Operations Contract for Service with the City of Elk Grove (“Operations Contract”) establishes a five-year term, with service provided by SacRT commencing on July 1, 2019, for a total value of approximately \$36 million.

Revised term: It is the current intent that during this Contract’s term, the City and SacRT will discuss the annexation of the City’s transit services into SacRT’s jurisdiction. This discussion will commence no later than June 30, 2020. If the City determines that SacRT’s performance for the first year exceeds the City’s previous contractor, MV Transportation, during the last fiscal year of its contract, then City will consider, and negotiate in good faith, annexation to SacRT’s jurisdiction.

New term: Either City or SacRT may terminate the contract for convenience with 270 calendar day’s written notice to the other party.

Compensation Methodology

SacRT submitted an initial cost proposal to City for the proposed services in February 2018. Since that time, there have been refinements to and escalation of some of the costs from the initial

Agenda Item No.	Board Meeting Date	Open/Closed Session	Information/Action Item	Issue Date
6	03/11/19	Open	Action	03/06/19

Subject: Agreement with the City of Elk Grove for Transit Services

proposal. In the pricing proposal, SacRT calculated all of the anticipated fixed and variable contract costs. The annual fixed costs are divided by 12 to calculate a fixed Monthly Administrative Cost. The annualized variable costs were divided by the estimated number of annual revenue hours for both fixed-route and paratransit service to create a blended hourly cost for revenue service. SacRT will be paid for the variable costs on the basis of the number of revenue service hours actually provided in a given month. Both the monthly fee and the per hour costs will be escalated by 3% each fiscal year. Reasons that costs might exceed the estimate would include: labor cost increases; payment of claims that fall within SacRT’s self-insured retention; or greater than anticipated maintenance costs due to the age of the City’s bus fleet.

SacRT does not have the right to request additional compensation if its costs exceed the estimates. Because of this, there is some cost risk to SacRT’s operating budget by entering into the Operations Contract. However, that cost risk is mitigated somewhat by SacRT’s ability to terminate the Operations Contract for convenience with 270 calendar days’ written notice to the City.

Terms of Performance

Under the Operations Contract, which contains many of the provisions that are currently included in the City’s contract with MV Transportation, SacRT would be responsible for operational and operational support activities, scheduling, and fare revenue collection for fixed route and ADA paratransit services, as well as the maintenance of service revenue vehicles, a portion of a shared City facility, and bus stop signs and shelters. SacRT’s performance of these services must also comply with the following key provisions:

Key Staffing: SacRT must ensure that key staff positions remain filled for the duration of the agreement. The key positions are the Operations Superintendent, Maintenance Supervisor, Operations Training Specialist, and Data Analyst.

Reporting: SacRT must provide daily, monthly, and occurrence based performance reporting to the City. SacRT is also responsible for tracking and reporting National Transit Database information and other federally required information.

Liquidated Damages: Similar to the current contract between the City and MV Transportation, SacRT would be subject to liquidated damages for not meeting certain contract requirements. These include: (1) failure to comply with all material elements of SacRT’s Transition Plan that are integral to service delivery beginning July 1, 2019, or failure to materially comply with contract termination requirements (5% of the monthly administrative fee); (2) failure to permanently fill vacancies in “key positions” described above (liquidated damages equal to the daily compensation for each day the position is left vacant beyond 90 days); (3) failure to comply with operational performance metrics after an initial 90-day grace period (generally unless cause was beyond SacRT’s control), including: failure to maintain a system-wide unclassified revenue rate of 15% (\$250 a month), missed trips (*now \$ 150 per trip starting, excluding the first two occurrences and other excused missed trips*), failure to pick up passengers (*now \$100 per verified pass-up*), late

Agenda Item No.	Board Meeting Date	Open/Closed Session	Information/Action Item	Issue Date
6	03/11/19	Open	Action	03/06/19

Subject: Agreement with the City of Elk Grove for Transit Services

first stops (\$50 per late first stop per route block of work, excluding the first two occurrences and other excused occurrences), failure to timely submit reports to City (*now \$100 per occurrence and limited to NTD reports*), late paratransit pick-ups (\$50 per occurrence, excluding the first and other excused occurrences), missed paratransit pick-ups (*now \$150 per occurrence, excluding the first and other excused occurrences*), failure to secure a paratransit passenger (\$250 per verified occurrence); (4) failure to meet maintenance performance metrics, including failure to clean a vehicle per the schedule and criteria (*now \$50 per occurrence excluding the first and other excused occurrences*), failure to conduct preventive maintenance per the schedule (\$250 per monthly occurrence per bus), annual CHP inspection failure (\$2,500 for the first occurrence, with escalation for subsequent failures), failure to repair a bus stop sign or shelter within 7 days (\$50 per occurrence unless repair is not possible within 7 days), and failure to clean a bus stop sign or shelter (*now \$50 per occurrence after 3 days' notice from City*).

Revised term: Liquidated Damages Dispute Process: If SacRT disputes a determination by City's Transit System Manager on the assessment of liquidated damages, SacRT may submit a request that the assessment be reviewed by the City Manager, who will review and make a determination *in consultation with SacRT's General Manager/CEO*.

New term: Possible Reduction or Elimination of Liquidated Damages: *Prior to June 30, 2021, SacRT and City will confer in good faith to determine whether, due to SacRT's satisfactory Contract performance, it would be in the best interests of SacRT and City, for administrative and other reasons, to reduce or eliminate the liquidated damage assessments for the remaining Contract term. Any proposed reduction will be effective upon the written approval of an authorized representative from both parties.*

Revised terms: Reductions in Liquidated Damage Assessments:

- (1) *Failure to comply with all material elements of SacRT's Transition Plan that are integral to service delivery beginning July 1, 2019: assessment will only apply to the first month of service. If SacRT has not satisfied the Transition Plan requirements by August 1, 2019, SacRT must reimburse the City for additional staff costs, resources, and other damages City may expend as a result of SacRT failing to implement transition requirements as set forth in the contract.*
- (2) *Failure to permanently fill vacancies in "key positions" within 90 days: City will not assess liquidated damages if SacRT provides a full time equivalent employee who will dedicate all their time to City's operations and be located at the City's Corporation Yard until an acceptable, permanent replacement is found.*
- (3) *Missed trips on fixed route service: assessment reduced from \$250 to \$150 (still excluding the first two occurrences and other excused missed trips).*
- (4) *Failure to pick up passengers on fixed route service: assessment/reimbursement reduced from \$500 to \$100 per verifiable occurrence, with an additional exception*

Agenda Item No.	Board Meeting Date	Open/Closed Session	Information/Action Item	Issue Date
6	03/11/19	Open	Action	03/06/19

Subject: Agreement with the City of Elk Grove for Transit Services

added for when a bus is at seating and standing capacity for non-ADA passengers, or there is no secured seating for ADA passengers.

- (5) *Failure to timely submit reports to City: now only applies to NTD sampling and monthly reporting with the assessed amount reduced from \$500 to \$100 per occurrence. However, SacRT must provide all required monthly reporting before City will be obligated to pay SacRT's monthly invoice for services.*
- (6) *Missed pickup for ADA paratransit service: assessment reduced from \$250 to \$150 (still excluding the first occurrence and other excused missed trips).*
- (7) *Failure to clean vehicles per the schedule: no assessment for first unexcused incident per bus per month.*
- (8) *Failure to clean bus stops or shelter per the schedule: no assessment if cleaned within 3 days of City notice to SacRT that a shelter has not been cleaned.*

Indemnity: Each party must indemnify, defend, and hold harmless the other party for any claims, damages, etc. resulting from that party's negligent acts or omissions (but the City has no such obligation for claims resulting from SacRT's responsibilities under the agreement).

Warranties: Upon execution, SacRT and the City would jointly go through an inspection process of all facilities, vehicles, equipment, goods, and services, to be supplied by the City for SacRT's use to identify and address any material defects. SacRT would not be obligated to perform services under the contract if the failure is due to any identified but unresolved material defects. However, following SacRT's acceptance of the facilities, vehicles, equipment, goods, and services, the City would make no further warranty, with an exception for major powertrain components for engine, transmission, and differential overhauls or replacements for the City's revenue service vehicles.

Insurance: SacRT must maintain, at a minimum, the following insurance coverage: (1) Commercial general liability (\$5,000,000 per occurrence), (2) Commercial automobile coverage (combined single limit of \$5,000,000), (3) Comprehensive and collision/physical damage (\$10,000,000 per occurrence/\$500,000 per vehicle), Garagekeepers (\$500,000 per occurrence/\$1,000,000 aggregate), On-Hook/Cargo (\$500,000 per occurrence/\$1,000,000 aggregate), (4) Workers' Compensation and Employer's Liability (\$1,000,000 per occurrence), (5) Umbrella and Excess Liability policy (\$20,000,000 per occurrence), (6) Employee dishonesty/fidelity bond (\$1,000,000 per occurrence), and (7) Pollution legal liability (\$1,000,000 per occurrence).

Facility: SacRT would lease a portion of the City Corporation yard in Elk Grove to perform transit services under the Operations Contract, including administrative operations, dispatch, maintenance, potential fueling, and parking. SacRT would be responsible for maintaining the portion of the shared facility exclusively reserved for SacRT, with the exception of shared systems

Agenda Item No.	Board Meeting Date	Open/Closed Session	Information/Action Item	Issue Date
6	03/11/19	Open	Action	03/06/19

Subject: Agreement with the City of Elk Grove for Transit Services

such as fire suppression and heating ventilations and air conditioning (HVAC), as well as landscaping, custodial services, and pest control.

Service and Fares

Under the Operations Contract, SacRT would operate all routes that the City currently identifies as available to the public. This service is described in Exhibit “I” of the Operations Contract, and includes six local routes, ten commuter routes, as well as four Saturday routes, and daily dial-a-ride/ADA paratransit service at the same level operated today. The service would be operated out of the Elk Grove Corporation yard with City-owned and branded transit vehicles as it is today.

In addition, the Operations Contract addresses the possibility of SacRT providing system-wide or regional paratransit services. The parties intend to commence negotiation on regional paratransit service immediately, with a goal of July 1, 2019 implementation. The method of providing regional paratransit services and the fares for such service are subject to future negotiation with both Paratransit, Inc. and the City.

*New Term: **Branding:** SacRT will have the right to incorporate its logo/branding decal on City-owned revenue service vehicles, subject to the City’s final approval and determination of the logo/branding decal’s size, location, and composite materials.*

*New Term: **Fare Integration:** During the term of this Contract, City and SacRT will work towards improved fare integration between the two systems for the greater convenience of the traveling public, and pursue amendments to any applicable transfer agreements between the parties as necessary to achieve that objective.*

Employment

All e-van and e-tran employees are currently employees of MV Transportation. The drivers, reservationists, dispatchers, mechanics, technicians and utility workers are represented by the Amalgamated Transit Union Local 256 (ATU). The supervisors and managers are non-represented.

SacRT’s intent is to offer employment to all qualified employees who would like to continue serving in the City. SacRT has authorized 98 new positions for the Elk Grove operation. All MV employees who apply and meet the minimum qualifications for a position would be invited to an interview with SacRT and offered employment upon successful completion of an interview and pre-employment screening, and training. SacRT’s goal is to make the transition as seamless as possible.

SacRT is currently coordinating with ATU to establish an agreement for the SacRT employees who would be in the Elk Grove bargaining unit, with the intent of having similar terms to the current agreement between ATU and MV Transportation. This would include all employees currently

Agenda Item No.	Board Meeting Date	Open/Closed Session	Information/Action Item	Issue Date
6	03/11/19	Open	Action	03/06/19

Subject: Agreement with the City of Elk Grove for Transit Services

represented by ATU if they elect to become SacRT employees. SacRT has committed to the City and ATU that employees will receive comparable wages, improved medical benefits and an increase over the current deferred compensation contribution. Because the details of the labor agreement have not yet been finalized, the uncertainty surrounding labor costs represents one of the biggest risks of the Operations Contract.

Organization

Under the direction of the SacRT Director of Transportation, the Operations Superintendent will have primary responsibility for delivery and monitoring of transit operations and maintenance under the contract, including oversight and supervision of dispatch supervisors, bus operators, maintenance employees, and customer service staff. The current contract management structure is described in the following chart.

Contract Management Structure:

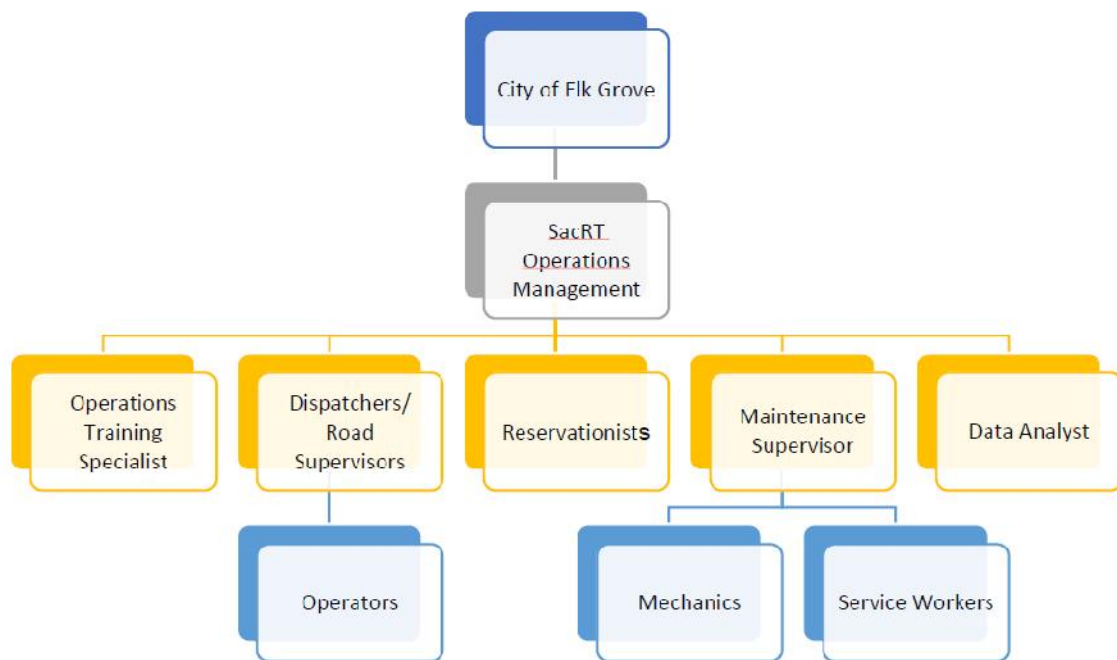

Benefits and Opportunities

As stated previously, the SacRT contract with the City would provide a fair and reasonable compensation package to operators, dispatchers, customer service representatives and maintenance staff. The City’s report to Elk Grove City Council on December 12, 2018 explained that MV Transportation and other private operators have experienced a driver shortage over the past year. City staff stated that the shortage has stemmed primarily from a robust economy with low unemployment that has offered potential bus drivers more competitive wages and benefits in sectors outside of privately operated public transit. The City described late and missed trips due

Agenda Item No.	Board Meeting Date	Open/Closed Session	Information/Action Item	Issue Date
6	03/11/19	Open	Action	03/06/19

Subject: Agreement with the City of Elk Grove for Transit Services

to lack of available drivers. With more competitive wages/benefits, and a larger pool of available drivers, SacRT will likely provide greater driver retention and availability for City transit services and improved service quality.

SacRT also offers economies of scale through the consolidation of certain administrative functions and staff. SacRT can provide additional resources including experienced transit scheduling personnel who will analyze run-cutting (schedule-making) for e-tran service to further evaluate and improve on-time performance issues. SacRT’s experienced transit operations staff will expand the depth and breadth of available resources for the City transit service.

Additional benefits include the ability to collaborate more effectively on regional transit operations and long-range capital and strategic planning efforts. Contracting with the City will provide SacRT the opportunity to understand the City’s transit operations and future transit objectives, while still allowing the City to maintain oversight and administration of transit services. With the recent annexation of the cities of Citrus Heights and Folsom, annexation may be considered by the City of Elk Grove after a successful contract term. Annexation offers an even stronger partnership between SacRT and the City, including broader economy of scale, and improving our ability to compete more successfully for regional, state and federal funding, benefitting the region as a whole.

Amendment to the Service Agreement

Currently, under the Service Agreement, the City pays \$350,000 per fiscal year in monthly installments of \$29,166.67 as its proportionate share payment to SacRT based on the benefits that light rail and other regional SacRT services provide to City residents. The term of the Service Agreement is July 1, 2017 through June 30, 2020. If SacRT and the City enter into the Operations Contract, the Services Agreement will be amended to provide that, beginning July 1, 2019, while the Operations Contract is in effect, the amounts paid to SacRT under the Contract for Service will be considered to satisfy the statutory proportionate share requirement. If the Operations Contract is terminated during Fiscal Year 2020, the City must resume the specified proportionate share payments for the remaining term of the Service Agreement.

Staff Recommendation

Staff recommends that the Board approve the Fixed Route, ADA Paratransit/Dial-A-Ride, and Maintenance Operations Contract with the City of Elk Grove and conditionally approve the Second Amendment to the Service Agreement with the City of Elk Grove contingent upon the City approving the Operations Contract.

RESOLUTION NO. 19-03-_____

Adopted by the Board of Directors of the Sacramento Regional Transit District on this date:

March 11, 2019

**APPROVING THE FIXED ROUTE, ADA PARATRANSIT/DIAL-A-RIDE, AND
MAINTENANCE OPERATIONS CONTRACT FOR SERVICE WITH THE CITY OF ELK
GROVE**

BE IT HEREBY RESOLVED BY THE BOARD OF DIRECTORS OF THE
SACRAMENTO REGIONAL TRANSIT DISTRICT AS FOLLOWS:

THAT, the Fixed Route, ADA Paratransit/Dial-A-Ride, and Maintenance Operations Contract for Service by and between the Sacramento Regional Transit District (therein "SacRT") and the City of Elk Grove (therein "City"), whereby SacRT agrees to provide fixed route, ADA Paratransit/Dial-a-Ride and maintenance services for a five-year period, beginning July 1, 2019 and ending June 30, 2024, and City agrees to compensate SacRT based on a fixed monthly administrative rate and a per hour rate for hours of revenue service actually provided, for a total amount not to exceed \$36 million, as further specified therein, is hereby approved.

THAT, the Chair and General Manager/CEO are hereby authorized and directed to execute the foregoing agreement.

PATRICK KENNEDY, Chair

A T T E S T:

HENRY LI, Secretary

By: _____
Cindy Brooks, Assistant Secretary

RESOLUTION NO. 19-03-_____

Adopted by the Board of Directors of the Sacramento Regional Transit District on this date:

March 11, 2019

CONDITIONALLY APPROVING THE SECOND AMENDMENT TO THE SERVICE AGREEMENT WITH THE CITY OF ELK GROVE

BE IT HEREBY RESOLVED BY THE BOARD OF DIRECTORS OF THE SACRAMENTO REGIONAL TRANSIT DISTRICT AS FOLLOWS:

THAT, the Second Amendment to the Service Agreement between the Sacramento Regional Transit District (therein "SacRT") and City of Elk Grove (therein City") whereby SacRT agrees to treat payments made by City under the Fixed Route, ADA Paratransit/Dial-A-Ride, and Maintenance Operations Contract for Service ("Operations Contract") as City's "proportionate share" contribution toward regional transit service for Fiscal Year 2020, beginning July 1, 2019 and ending June 30, 2020, is hereby conditionally approved, pending execution of the Operations Contract.

THAT, the Chair and General Manager/CEO are hereby authorized and directed to execute the Second Amendment following full execution of the Operations Contract.

PATRICK KENNEDY, Chair

A T T E S T:

HENRY LI, Secretary

By: _____
Cindy Brooks, Assistant Secretary

REGIONAL TRANSIT ISSUE PAPER

Agenda Item No.	Board Meeting Date	Open/Closed Session	Information/Action Item	Issue Date
7	03/11/19	Open	Action	03/08/19

Subject: Florin Light Rail Station Use Update

ISSUE

Update on potential future use of property at the Florin Light Rail Station for a homeless shelter.

RECOMMENDED ACTION

None.

FISCAL IMPACT

None as a result of this information item.

DISCUSSION

The City of Sacramento (City) is requesting a 30-month lease of approximately two acres of the Florin Light Rail Station parking lot for a temporary homeless shelter to house up to 100 beds. The proposed location is in the northwest corner of the paved parking lot (Attachment 1). It is bordered by Florin Road on the south, a grass field on the north, a mobile home park to the east and housing on the west.

After the expansion of the Blue Line to Cosumnes River College in 2015, parking demands at the Florin Station have dropped due to it no longer being near the terminus of the line. There are 1,074 parking spots at the station, but only about 50-200 spots are occupied on a daily basis. SacRT acquired the land with state and federal funds, which requires SacRT to receive fair market value from a lease and concurrence from the Federal Transit Administration (FTA).

City staff has been working with SacRT staff to evaluate the site's opportunities and constraints. This is the first of several efforts throughout the City to identify suitable sites for those persons experiencing homelessness. According to the City, each site would (1) be utilized by referral only, (2) have 24 hour staffing and case management services, and (3) have housing supporting services and coordination with other service providers.

The City has conducted outreach with the surrounding neighborhood:

- January 29 - Community Forum at Burbank High School
- February 5 - Florin Road Partnership Security meeting
- February 16 – Indian Lane resident meeting
- February 21 – Golf Course Terrace Estates Neighborhood Association – general membership meeting

Additionally, Councilmember Schenirer and District 5 staff are meeting directly with community members who have requested meetings around the issue and are planning forums that accommodate Hmong and Spanish speaking residents of the neighborhood. The City has also

Approved:

Presented:

Revised Final 03/08/19

General Manager/CEO

VP, Finance/Chief Financial Officer

J:\Board Meeting Documents\2019\04 March 11, 2019\Florin Light Rail Station Use Update.doc

Agenda Item No.	Board Meeting Date	Open/Closed Session	Information/Action Item	Issue Date
7	03/11/19	Open	Action	03/08/19

Subject: Florin Light Rail Station Use Update

formed a monthly Advisory Group (of which SacRT staff is a participant), which initially met on February 19 and has been tasked with developing a “Good Neighbor Policy” with the surrounding neighborhoods and schools. The draft site plan and samples of the proposed structures are in Attachment 2.

Details about the Homeless Triage Center provided by City

- Successful locations must have access to transit, access to water and electrical utilities, and enough space for up to 100 people, their belongings, pets, and operations and services. Quick construction for the upcoming winter requires an existing paved lot with nearby utility connections.
- *Potential Shelter guests:* Access to the triage shelter is by referral only. There are no walk-up referrals to the site, or a waiting list for beds. The City’s Police Impact Team and Outreach partners through the City’s Pathways to Health and Home Program will identify people in need of shelter and arrange for intake and transportation. The City will give priority to individuals experiencing homelessness currently unsheltered in the immediate community. City Impact Team members believe a 100-bed shelter could be filled with homeless people residing in the immediate Florin/South Sacramento area almost immediately.
- *Timing of Shelter Operation:* The City is requesting a 30-month lease that will commence upon a signed agreement between the City and SacRT. This will provide the necessary 6-8 months to construct the shelter and allow operations through the winters of 2019 and 2020. Any extension of the lease would require a proactive decision of the SacRT Board and the City Council.
- The City recognizes that SacRT is proceeding on developing a Transit Oriented Development on the site and will coordinate its efforts with SacRT to not interfere with future development opportunities.
- *Shelter Operations:*
 - The City will seek a partnership from an experienced shelter operator via a public bid process. Final approval of the operator (via a funding agreement) will be considered by the City Council in a public session. City staff will retain direct oversight of the shelter in cooperation with the chosen partner, including facility maintenance and coordination of services.
 - The triage shelter would be open to guests 24 hours a day, seven days a week. There will be restrooms and showers on site. Guests will be provided three meals a day, as well as a variety of services and programming to encourage guests to stay on site and work toward housing, employment, or other individualized goals. Guests will be given a transit pass/Connect card (purchased by the City) which will address one of the challenges to accessing services and long-term employment – access to transportation.
 - There will be activity in and around the shelter – case managers, health care workers, etc. will come and go as with any business or service delivery organization.

Agenda Item No.	Board Meeting Date	Open/Closed Session	Information/Action Item	Issue Date
7	03/11/19	Open	Action	03/08/19

Subject: Florin Light Rail Station Use Update

For the City’s Railroad Shelter in the north area, the City’s Community Development Department did an environmental review that determined minimal vehicular impacts.

- **Safety and Security:**
 - The site would be enclosed by a fence surrounding the entire shelter area.
 - Access to the shelter facility is limited – there will be 24 hour on-site staffing of the shelter by the service provider.
 - For surrounding neighborhoods, the City would increase police patrols and solid waste cleanup in the immediate vicinity.
 - To support SacRT’s needs for improved transit security patrols, the City will lease a trailer for SacRT Police Service staff to be situated next to the light rail station and bus transfer area. A trailer will allow existing Transit Officers patrolling along the Blue Line to more easily address issues and could allow for increased security camera support and serve as a substation for SacRT Police Services.
 - The City will work with the principal of Burbank High School, and the Law and Social Justice Academy, and other neighboring schools regarding student educational opportunities related to the shelter. Sacramento Police Department will prioritize student and rider safety in the immediate area.
- **Shelter and Station Area Maintenance and Cleaning:** The contracted shelter provider would be responsible for daily operation of the shelter site, and the City facility department would be responsible for maintenance of the site and buildings. In addition, the City would identify resources to provide a Downtown Streets Team (DST) comprised of (homeless) individuals for maintenance and cleaning of the area surrounding the shelter as well as the light rail station. DST will give preference on their work teams for shelter guests or others experiencing homelessness in the immediate area.

License Agreement Terms between City and SacRT

At the January 28, 2019 Board meeting, the Board directed Staff to work with the City to determine if SacRT would be legally able to lease a portion of the Florin station property to the City for a homeless shelter and what terms and conditions would be required. Staff has drafted the following list of salient terms and conditions. These are however subject to change and a more final term sheet and delegation of authority will be brought back to the Board for vote at a future meeting.

1. FTA Concurrence requirements:
 - a. Follow Circular: FTA C 5010.1E on Management of Real Property to determine if lease is “Incidental Use” or “Joint Development” and therefore which rules apply
 - b. Provide documentation to FTA that it will not impact transit ridership and park and ride usage
 - c. Provide documentation (third party appraisal) to FTA that lease will generate fair market revenue
 - d. Define clearly in license agreement the Responsible Parties for costs, liabilities, insurance, and safety from specific construction, operation and site use activities
 - e. Define clearly in license agreement the Return to Original Conditions and Responsible Parties (to ensure continued transit usage following lease duration)

Agenda Item No.	Board Meeting Date	Open/Closed Session	Information/Action Item	Issue Date
7	03/11/19	Open	Action	03/08/19

Subject: Florin Light Rail Station Use Update

- f. Obtain written approval from Region 9
- 2. Security Provisions to prevent impact to transit passengers and SacRT property. SacRT and City are working together on terms including surveillance, lighting and fencing.
- 3. Operating Costs
 - a. Utilities (covered by project)
 - b. Cleaning throughout station area by Downtown Streets Team
- 4. Modifications to site
 - a. Costs of site preparation and return to original condition (covered by project)
- 5. Indemnification clause protecting SacRT from any liability resulting from use of site and CEQA compliance

Both parties have discussed the monitoring of impacts. Transit ridership, passenger use of the station, crime incidents, and neighborhood homelessness statistics will all be tracked to assess the impacts of the facility throughout the duration of the lease.

Term sheet and specifics regarding operation and construction of the City Homeless Triage Center are subject to approval by the City Council. SacRT and City staff will work together to ensure the spirit of this proposed use will be met.

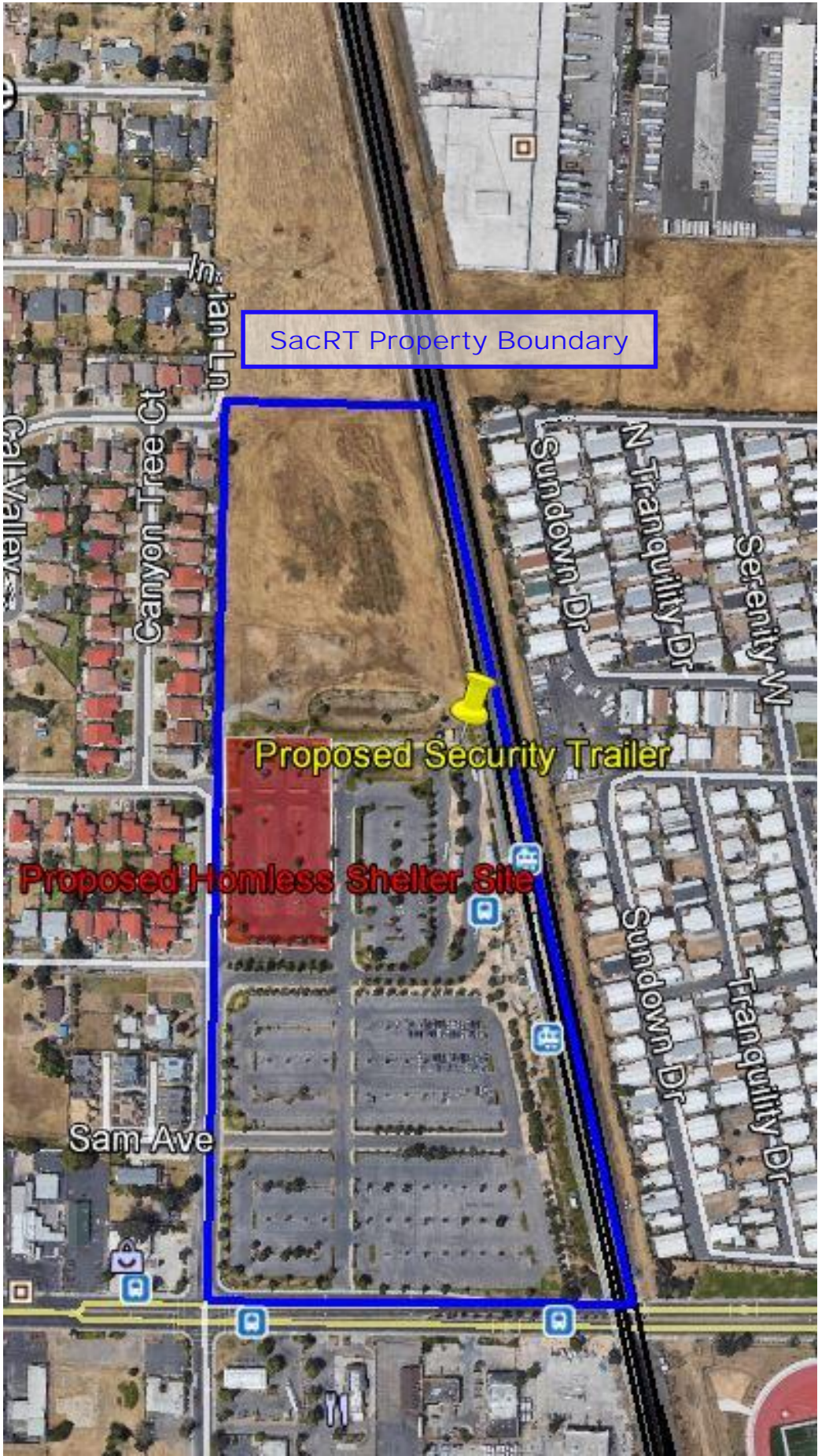



VICINITY PLAN

NTS

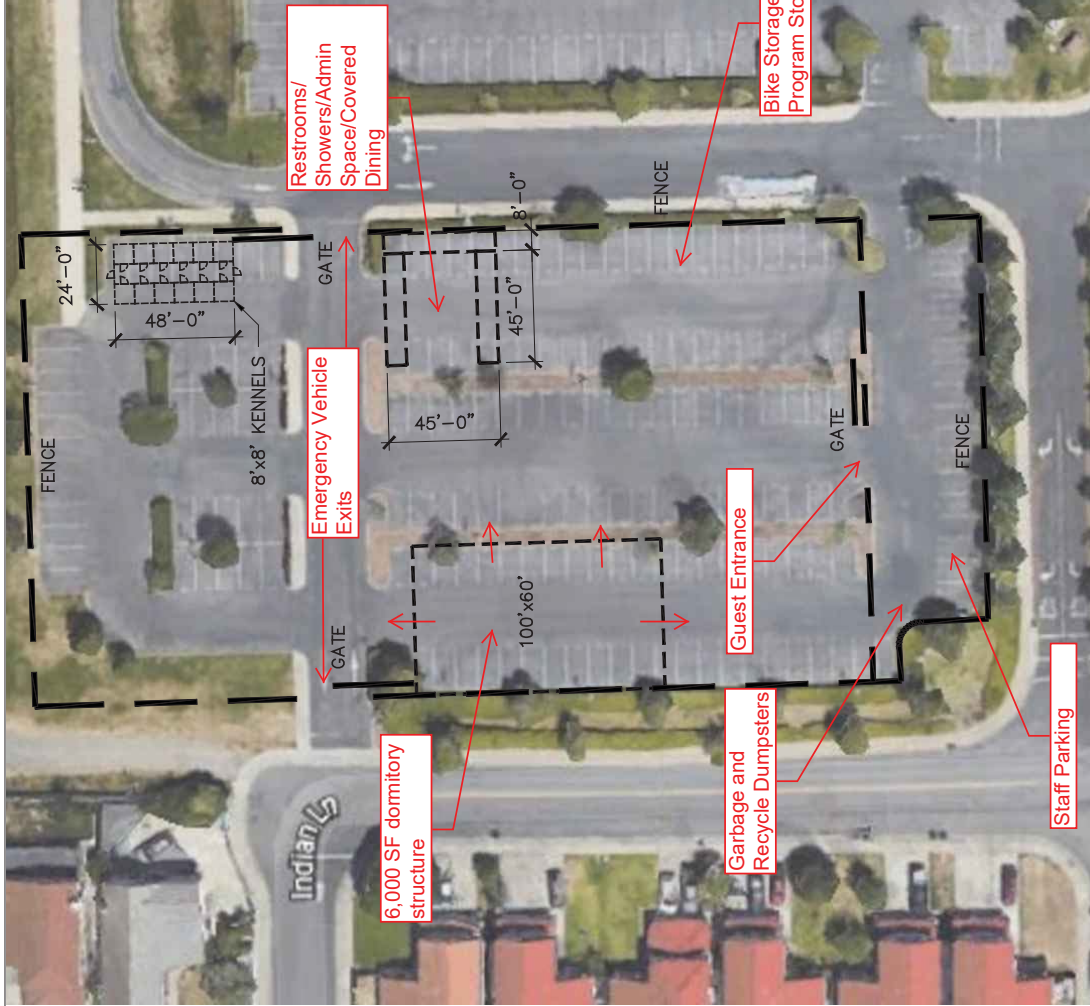

Attachment 2
Sheet No: A-1
1 OF 1

Work Order No: 2808287
Issue Date: 3/4/2019
Sheet Scale: 1"=50'

Designed By: AS
Drawn By: IM
Reviewed By: AS

No.	Comments / Remarks	Date

Project Name & Address:
FLORIN RD, LIGHT RAIL STATION
7029 INDIAN LANE
SACRAMENTO, CA 95822



Sheet Type / Description:
PROPOSED HOMELESS SHELTER
SITE PLAN

Dormitory Structure



Fresno Rescue Mission – Sprung Structures



Fresno Rescue Mission – Sprung Structures

Dormitory Structure



Division Circle Navigation Center, San Francisco – Sprung Structures

As one vendor of this type enclosure, Sprung Structures offers:

- Immediate delivery from Inventory
- Rapid Construction Schedule
- Spacious, Energy Efficient Environments
- Standard Daylight Panels
- Limited Foundation Requirements

CB = CABLE BRACING

7 PANELS @ 15'-0" = 105'-0"

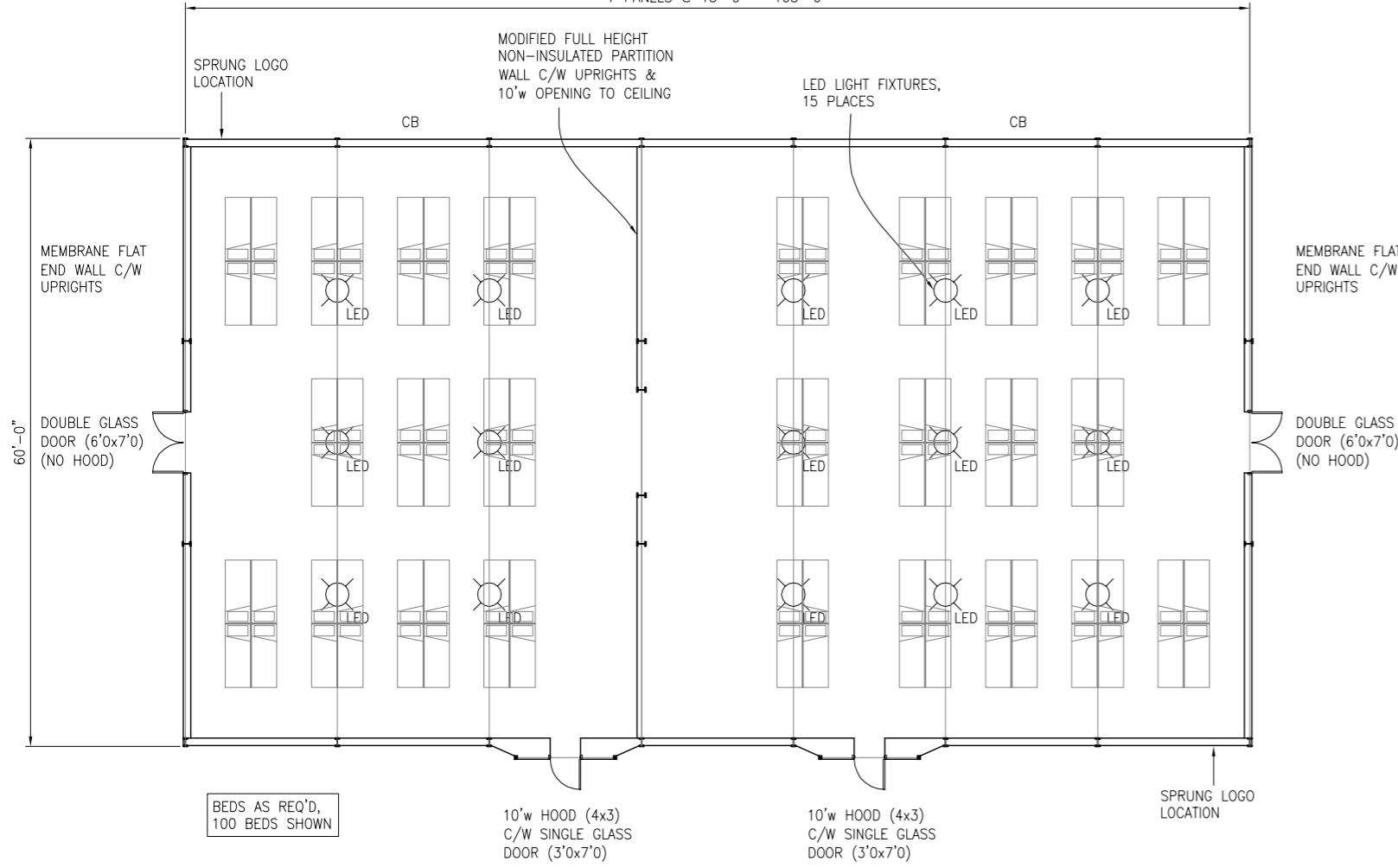

1 OPEN PLAN VIEW
026.0 1/8"=1'-0"

INTERIOR SHOWN FOR REFERENCE ONLY, FINAL LAYOUT DESIGNED & SUPPLIED BY OTHERS.

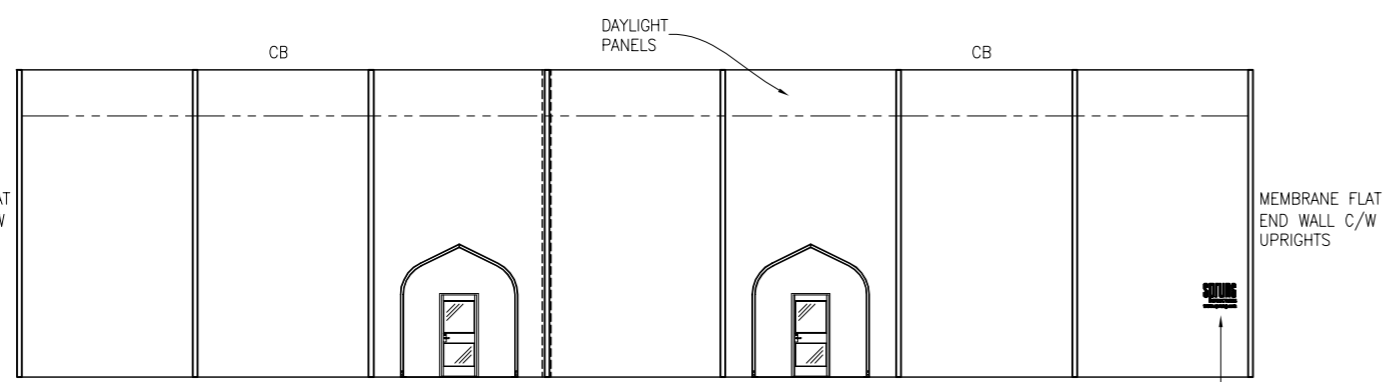

2 ELEVATION
026.0 1/8"=1'-0"

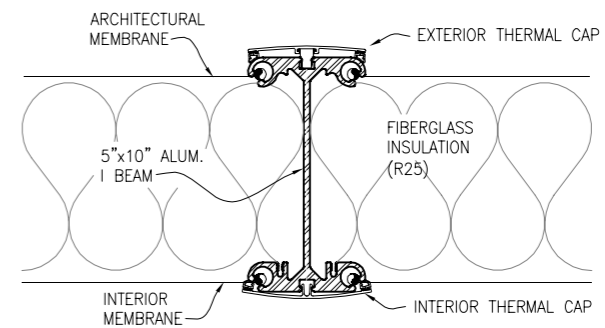

3 5"x10" INSULATED BEAM SECTION
026.0 3"=1'-0"

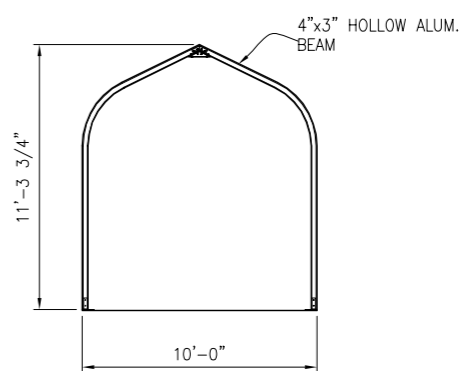

4 SECTION 10'-0" HOOD
026.0 1/4"=1'-0"

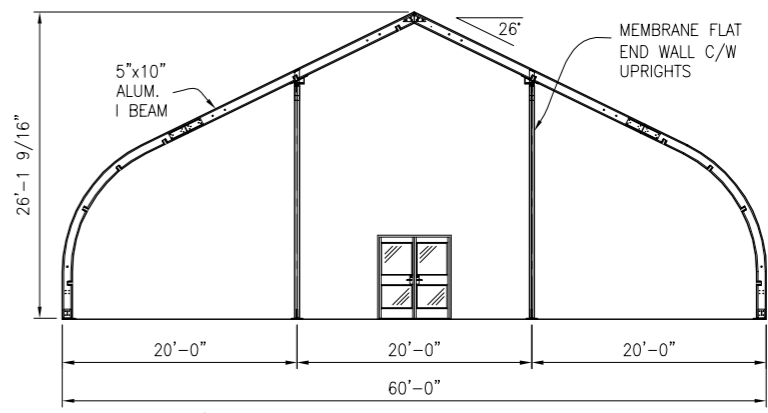

5 FLAT END 60'-0" INSULATED STRUCTURE
026.0 1/8"=1'-0"

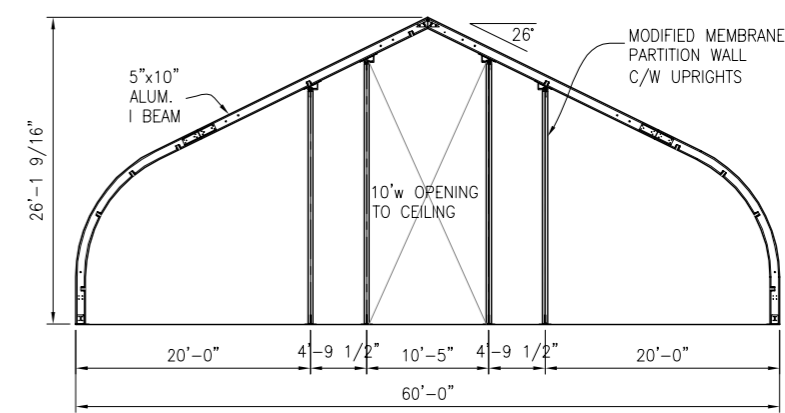

6 MODIFIED 60'-0" NON-INSULATED PARTITION WALL
026.0 1/8"=1'-0"

DRAWING APPROVAL

Signature _____

Print Name _____

Date: _____

Confirmation of wind speed at site per the local building dept.
Building Code: _____

_____ MPH, Exposure _____

Initial _____



innovation | versatility | reliability

TOLL FREE: 1-800-528-9899
or (403) 601-2292 www.sprung.com

GENERAL NOTES:

1. ALL PERSONNEL DOORS C/W PANIC HARDWARE & HOODS.
2. STRUCTURE TO BE INSULATED WITH FIBERGLASS BATT INSULATION C/W INNER LINER, TO DAYLIGHT PANEL LEVEL ONLY.
3. INNER & OUTER MEMBRANE TO BE FINISHED TO CONCRETE USING ALUM. FLAT BAR
4. STRUCTURE MEMBRANE MEETS: NFPA 701, CALIFORNIA STATE FIRE MARSHAL, ASTM E84, CAN/ULC-S-109 & CAN/ULC-S-102 SPECIFICATIONS.
5. THIS STRUCTURE IS DESIGNED TO SHED/RELEASE SNOW. THE PERIMETER OF THE STRUCTURE SHALL BE KEPT CLEAR.
6. WHEN DESIGNING A HEATING, VENTILATION OR AIR CONDITIONING SYSTEM FOR ANY TYPE OF BUILDING, IT IS IMPORTANT TO ENSURE THAT THIS SYSTEM INTAKES MORE AIR THAN IS BEING EXHAUSTED AT ANY GIVEN TIME. THIS PROCESS WILL RESULT IN A POSITIVE PRESSURE BEING MAINTAINED. CONVERSELY, IF NEGATIVE PRESSURE EXISTS WITHIN THE STRUCTURE, IT WILL BE DIFFICULT TO OPEN DOORS AND MOISTURE WILL BE DRAWN INTO THE STRUCTURE.
7. ALL INTERIOR WALLS & PARTITIONS (IF APPLICABLE) TO BE FREE STANDING & INDEPENDENT OF SPRUNG STRUCTURE.

SIGNATURE SERIES

REV.	MM/DD/YY	DESCRIPTION

This drawing is protected by copyright in the United States of America, Canada and all other countries of the world. It, and all of the designs, technical data and engineering services represented by it and originated or rendered by SPRUNG INSTANT STRUCTURES INC. are the exclusive property of SPRUNG INSTANT STRUCTURES INC. and must neither be used in manufacturing nor disclosed nor reproduced in whole or in part except with the prior written consent of SPRUNG INSTANT STRUCTURES INC. Any copying of this drawing in whole or in part and any use of it to construct the subject matter illustrated in it without prior written permission of SPRUNG INSTANT STRUCTURES INC. is prohibited.

CITY OF SACRAMENTO

60.0' x 105.0'
NAVIGATION CENTER - DORMITORY

DRAWN BY N. BUJT	DATE 01/21/2019
CHECKED BY	APP'D BY
SCALE AS NOTED	DRAWING # P19-026.0
CUST. APP'L	

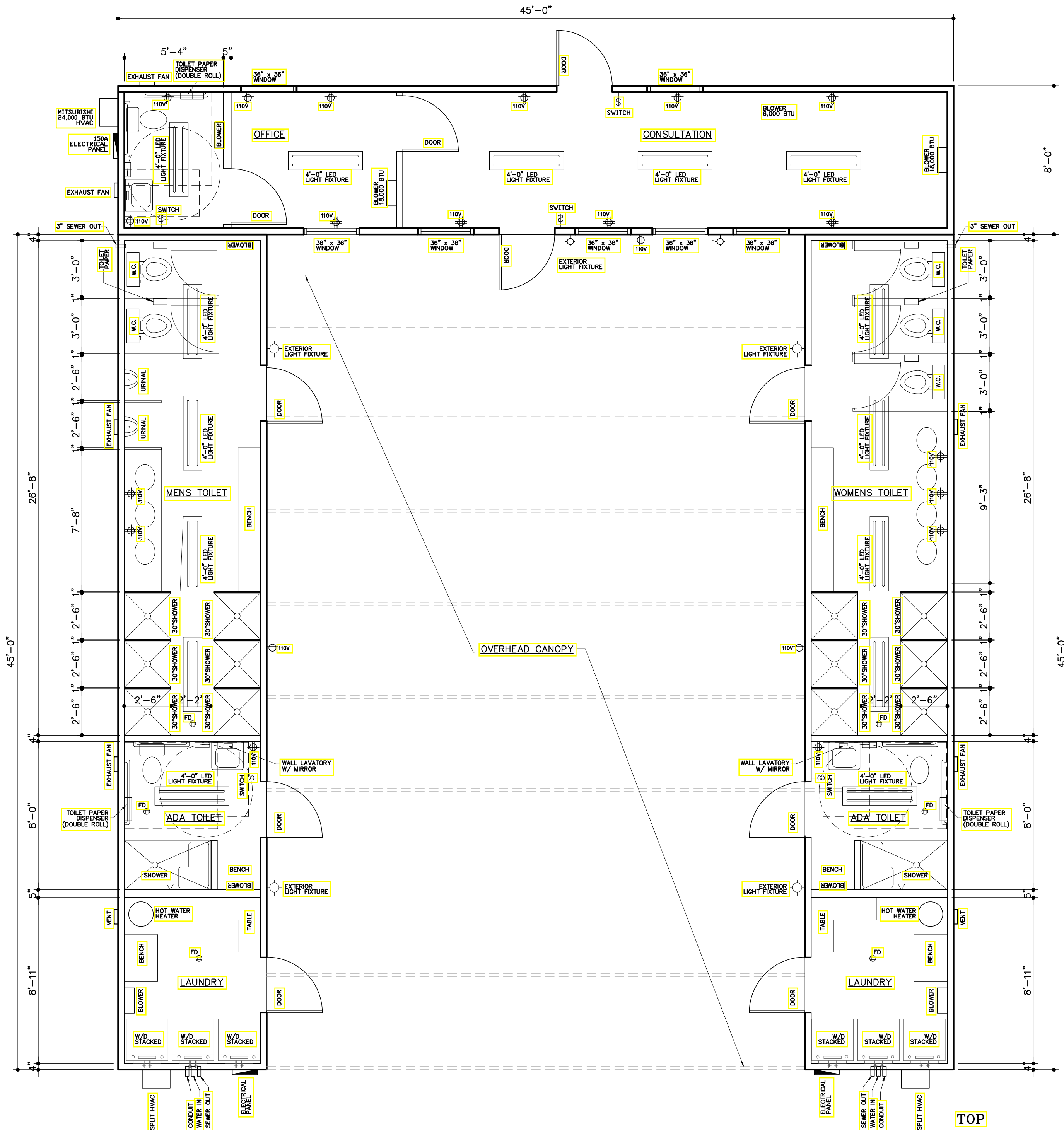

TOP

	GENERAL NOTES	AUTHORIZED SIGNATURE OF PRODUCTION	DRAWN BY W.G.	DATE 11/11/18
	CITY OF SACRAMENTO HOMELESS SHELTER	I HAVE REVIEWED ALL PLANS AND SPECIFICATIONS FOR THE PROJECT. I AUTHORIZE CONSENT OF DIAMOND BUILDERS INC. TO CONSTRUCT THE PROJECT AS IS. I UNDERSTAND THAT ANY CHANGES MADE TO THE FLOOR PLANS OR QUOTE WILL RESULT IN ADDITIONAL CHANGES.	BUILDING TYPE	SIZE
				QUOTE NUMBER
				SERIAL NUMBER

Linked Equipment Cargo Container Conversions



Typical Exterior View of a Converted Cargo Container.



Typical Exterior View of a Converted Cargo Container.

Linked Equipment Cargo Container Conversions



Interior views of Restroom/Shower Facilities.



Interior views of Restroom/Shower Facilities.

Perimeter Fencing



Green Privacy Screen over 8' Chain Link.

**General Manager's Report
March 11, 2019**

SacRT MEETING CALENDAR

Regional Transit Board Meeting

March 25, 2019
SacRT Auditorium
5:30 P.M

Quarterly Retirement Board Meeting

March 20, 2019
SacRT Auditorium
9:00 A.M

Mobility Advisory Council Meeting

April 4, 2019
SacRT Auditorium
2:30 P.M.